



PRODUCT CATALOG

كتالوج المنتجات



GBU



GBU



Always the best!

ABOUT US / معلومات عنا

Our dear business partners,

As GBU, We are a company working in the field of manufacturing and trading building materials since 1995. We are located in Istanbul, Türkiye

We respond to all demands of you, our dear business partners, with,

PVC window – door profile and components, accessory systems, support sheet groups, PVC joinery manufacturing machines, Double-glazing manufacturing machines, glass and Double-glazing production materials, PVC panel, Decorative panel, Aluminum or PVC fly net systems, PVC insulation materials, Aluminum glass balcony and all components which you will need with our wide product supply range.

You, our esteemed business partners, are those who will establish a new PVC joinery plant or aim to modernize their existing facility and increase their production capacity and production quality. If you wish, we set up your production facility on a turnkey basis with overseas technical support service and provide production trainings.

We provide support on the supply and sale, installation and technical training of all equipment such as double-glazing manufacturing, tempered glass manufacturing, double-glazing production materials (Thiyacol, double-glazing bead, dehumidifier).

In addition to these, we provide support on a project basis also for finished products (PVC window or door with glass mounted on it inside the case). We are glad to be your solution partner in all of your works on a project basis, which you have difficulty in addressing in your own market due to either the business density or the factors such as lack of capacity, lack of technical equipment and financial cost problem. In the same regard, we can provide support to you with either the ready team or a supervisor who can organize the existing team for the installation stages of the projects.

السادة العملاء

جي بي يو نحن شركة نعمل في مجال صناعة وتجارة مواد البناء منذ عام 1995 . الواقع مقرنا في تركيا إسطنبول : نسعد ان نقدم لكم مجموعة واسعة من المنتجات التي نعمل بها وهي

بروفيلات الأبواب والنوافذ من مادة ال بي في سي . أكسسوارات الأبواب والنوافذ . الحديد الداعم للبروفيلات . أبواب ونوافذ جاهزة للاستخدام . ماكينات . لصناعة الأبواب والنوافذ من مواد ال بي في سي والألمنيوم . ماكينات لصناعة الزجاج المزوج ذات الطبقتين . ماكينات غسل الزجاج ألواح البنل . مواد شبك البعوض . مواد العزل الكيميائية . واجهات الزجاج والألمنيوم و حديد الصاج المغلفن الداعم لبروفيلات ال بي في سي . بكافة القياسات وأيضاً نقدم لكم خدمة ماكينات لصناعة وقص الحديد الصاج الداعم للبروفيلات من ماكينات وقوالب حسب طلب السوق لكم . وتقدير الخدمات الفنية أثناء العمل ونستجيب لجميع طلبات شركائنا الكرام

السادة العملاء نعمل أيضاً في مجال صناعة الأبواب والنوافذ الجاهزة للتركيب مع الزجاج للمشاريع الضخمة وبكميات كبيرة مع إمكانية التركيب والتسليم بمكان المشروع مع الفريق الفني الخاص وأيضاً بأرسل العمالة للعمل بمكان المشروع السادة العملاء الذين يودون تأسيس شركة لصناعة الأبواب والنوافذ والذين يعملون في صناعة الأبواب والنوافذ ويودون تجديد وتوسيع المصنع لديهم . نقدم لكم ماكينات ذات التكنولوجيا العالية وبأسعار مناسبة وبدعم الفنيين لتشغيل الماكينات في مصنعكم ونقدم لكم السهولة في العمل من تجميع البضائع في مستودعاتنا ونقل البضائع مختلف الشركات وشحن البضائع لكافة الدول العربية من شحن جوي وبحري وببري .

INDEX / المحتويات

1

PROFILES / بروفيلات

- 1.1 Premier Series
- 1.2 60 mm Glass Bead
- 1.3 60 mm Auxiliary Profiles
- 1.4 Eco Ultra Series
- 1.5 70 mm Glass Bead
- 1.6 70 mm Auxiliary Profiles
- 1.7 Nasa Series
- 1.8 Nasa Auxiliary Profiles
- 1.9 Common Profiles

2

ACCESSORY / اكسسوارات

- 2.1 Tilt & Turn
- 2.2 Espagnolette
- 2.3 Locked Espagnolette
- 2.4 Lock & Cylinder
- 2.5 Locking Plates
- 2.6 Mullion Connectors
- 2.7 Handle Group
- 2.8 Hinge Group
- 2.9 Screw Group
- 2.10 Transom Group
- 2.11 Sliding Wheel
- 2.12 Safety Latch

3

FLYSCREEN ACCESSROY / اكسسوارات شبك بعوض

- 3.1 Aluminum Profile (Pleat/17x25/10x25)
- 3.2 Tulle/ Pleat/ Plain Tulle
- 3.3 Flyscreen Accessory
 - 3.3.1 Pleat Set
 - 3.3.2 Hinge
 - 3.3.3 Corner Joint
 - 3.3.4 Wheel
 - 3.3.5 Lock

INDEX / المحتويات

4 PANA STONE / الواح الرخام بي في سي

5 PANELS GROUP / مجموعة البنل

5.1 Plate Panels

5.2 Door Panels

6 DOUBLE GLASS GROUP / مجموعة السبيسر المزدوج

6.1 Double Glass Spacer

6.2 Butyl

6.3 Molecular Sieve

6.4 Polysulphide

6.5 Corner Connectors

6.6 Panaspacer Iso-Tech

7 ISOLATION GROUP / المواد العازلة سليكون

8 MACHINE GROUP / مجموعة الماكينات

7.1 PVC Processing Machines

7.2 Aluminium Processing Machines

7.3 Glass Machines

7.4 Wood Processing Machines

7.5 Support Sheet Machines

9 HANDRAIL GROUP / مجموعة الدرايزين

8.1 Handrail Profile

8.2 Handrail Accessory

10 HARDWARE GROUP / مجموعة المعدات الصناعية

11 OUR ACTIVITIES / مجموعة شركات جي بي يو جروب



GBU

Safe and durable!



Premier

Series

PREMIER KASA PROFİLİ / PREMIER FRAME PROFILE

Et Kalınlığı / Wall thickness : 2.4 mm (± 0.2)
Ağırlık / Weight : 1.060 kg/m
Kod / Code : 181010

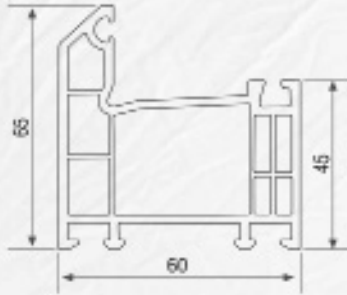

PREMIER KANAT PROFİLİ / PREMIER SASH PROFILE

Et Kalınlığı / Wall thickness : 2.4 mm (± 0.2)
Ağırlık / Weight : 1.260 kg/m
Kod / Code : 183010

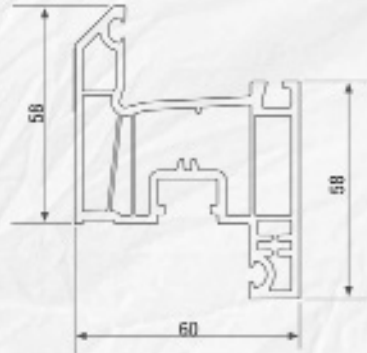

60 mm DIŐA AÇILIR KANAT PROFİLİ / 60 mm OUTSIDE OPENING SASH PROFILE

Et Kalınlığı / Wall thickness : 2.4 mm (± 0.2)
Ağırlık / Weight : 1.420 kg/m
Kod / Code : 141010

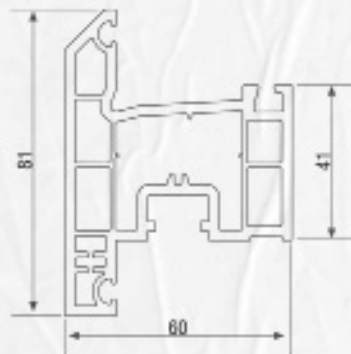

PREMIER İÇE AÇILIR KAPI PROFİLİ / PREMIER INNER OPENING DOOR PROFILE

Et Kalınlığı / Wall thickness : 2.4 mm (± 0.2)
Ağırlık / Weight : 1.610 kg/m
Kod / Code : 104210

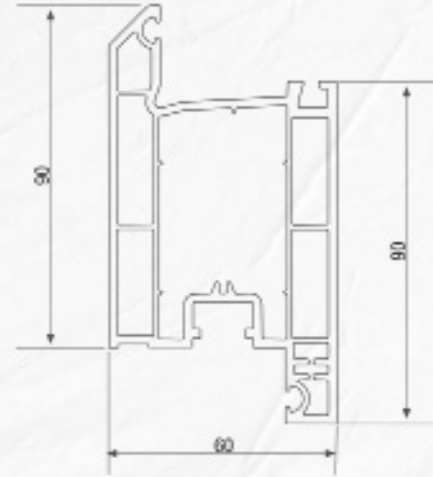

60 mm DIŐA AÇILIR KAPI PROFİLİ / 60 mm OUTSIDE OPENING DOOR PROFILE

Et Kalınlığı / Wall thickness : 2.4 mm (± 0.2)
Ağırlık / Weight : 1.610 kg/m
Kod / Code : 104410

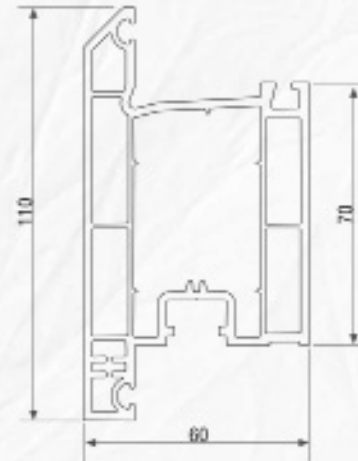

60 mm Glass Bead

Series

RADÜSLÜ TEK CAM ÇİTASI /
RADIUS SINGLE GLASS BEAD
Et Kalınlığı / Wall thickness : 2.4 mm (± 0.2)
Cam Kalınlığı / Glass thickness : 4, 5, 6
Kod / Code : 105032

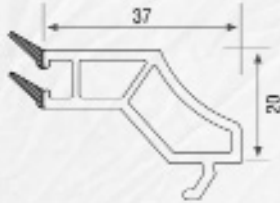

24 mm ÇİFT CAM ÇİTASI /
24 mm DOUBLE GLASS BEAD
Et Kalınlığı / Wall thickness : 2.4 mm (± 0.2)
Cam Kalınlığı / Glass thickness : 23, 24, 25
Kod / Code : 105572

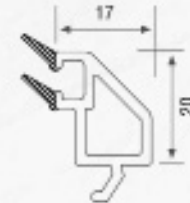

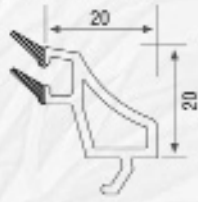

RADÜSLÜ ÇİFT CAM ÇİTASI /
RADIUS DOUBLE GLASS BEAD
Et Kalınlığı / Wall thickness : 2.4 mm (± 0.2)
Cam Kalınlığı / Glass thickness : 19, 20, 21
Kod / Code : 105072



KONİK ÜÇ CAM ÇİTASI /
CONIC TRIO GLASS BEAD
Et Kalınlığı / Wall thickness : 2.4 mm (± 0.2)
Cam Kalınlığı / Glass thickness : 30, 31, 32
Kod / Code : 105552

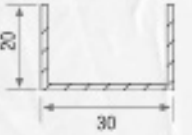

KASA - KANAT - ORTA KAYIT / FRAME - SASH - MULLION		KAPI KANAT / DOOR SASH		MENTEŞE LAMA SACI / HINGE	
	1.2 mm 618 gr 1.5 mm 761 gr 2.0 mm 983 gr		1.2 mm 1.273 gr 1.5 mm 1.580 gr 2.0 mm 2.075 gr		1.2 mm 70 gr

60 mm Auxiliary Profiles

Series

60x100 mm GRİYAJ PROFİLİ / 60x100 mm ENLARGING PROFILE

Et Kalınlığı / Wall thickness : 2.0 mm (± 0.2)

Ağırlık / Weight : 0.950 kg/mt

Kod / Code : 112000

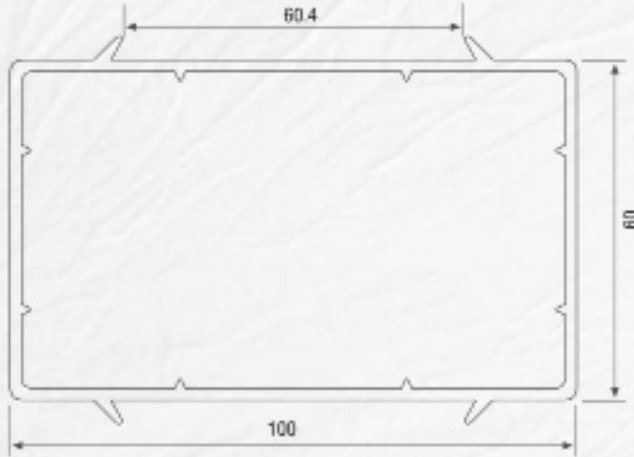

60 mm 135° KÖŞE DÖNÜŞ ADAPTÖR PROFİLİ /

60 mm 135° ANGLED CORNER ADAPTOR PROFILE

Et Kalınlığı / Wall thickness : 2.5 mm (± 0.2)

Ağırlık / Weight : 0.870 kg/mt

Kod / Code : 116000

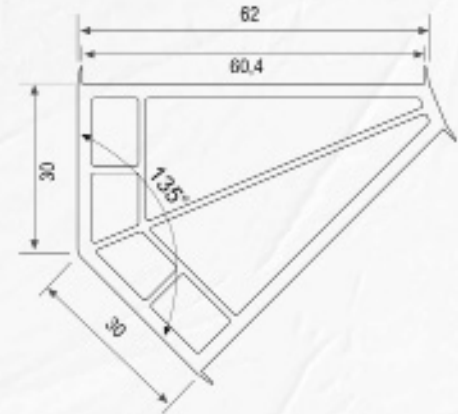

40x60 mm YÜKSELTME PROFİLİ / 40x60 mm LIFTING-UP PROFILE

Et Kalınlığı / Wall thickness : 3.0 mm (± 0.2)

Ağırlık / Weight : 0.950 kg/mt

Kod / Code : 117000

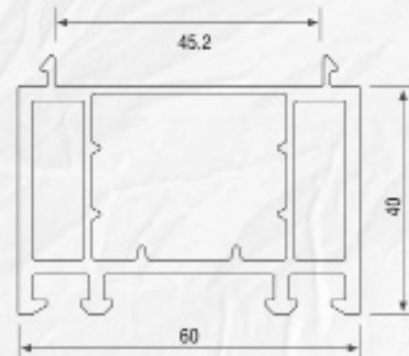

60 mm AÇILI DÖNÜŞ ADAPTÖR PROFİLİ /

60 mm ANGLED CORNER ADAPTOR PROFILE

Et Kalınlığı / Wall thickness : 2.5 mm (± 0.2)

Ağırlık / Weight : 0.550 kg/mt

Kod / Code : 114000

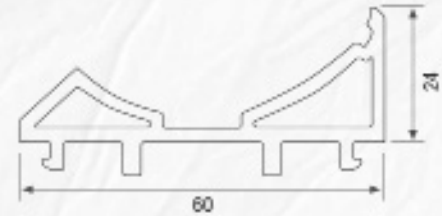

60 mm ALÜMİNYUM EŞİK PROFİLİ /

60 mm ALUMINIUM THRESHOLD PROFILE

Et Kalınlığı / Wall thickness : 2.5 mm (± 0.2)

Ağırlık / Weight : 0.580 kg/mt

Kod / Code : 109011



AÇILI DÖNÜŞ BORU PROFİLİ /

ANGLED CORNER PIPE PROFILE

Et Kalınlığı / Wall thickness : 2.0 mm (± 0.2)

Ağırlık / Weight : 0.710 kg/mt

Kod / Code : 115000



Eco Ultra Series

EKO ULTRA KASA PROFİLİ / ECO ULTRA FRAME PROFILE

Et Kalınlığı / Wall thickness : 2.4 mm (± 0.2)

Ağırlık / Weight : 1.200 kg/m

Kod / Code : 191010

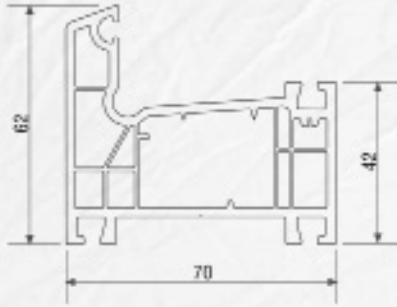

EKO ULTRA ORTA KAYIT PROFİLİ /

ECO ULTRA MULLION PROFILE

Et Kalınlığı / Wall thickness : 2.4 mm (± 0.2)

Ağırlık / Weight : 1.330 kg/m

Kod / Code : 192010

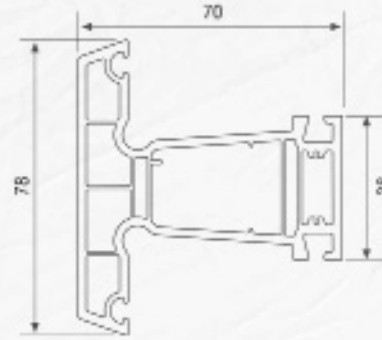

70'LİK PERVAZLI KASA PROFİLİ / 70 mm FRAME PROFILE (With Casing)

Et Kalınlığı / Wall thickness : 2.4 mm (± 0.2)

Ağırlık / Weight : 1.270 kg/m

Kod / Code : 193010

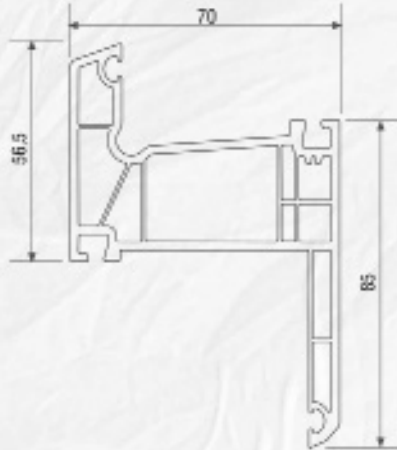

70 mm PİVOT KANAT ADAPTÖR PROFİLİ / 70 mm PIVOT SYSTEM - SASH PROFILE

Et Kalınlığı / Wall thickness : 2.4 mm (± 0.2)

Ağırlık / Weight : 1.090 kg/m

Kod / Code : 178010

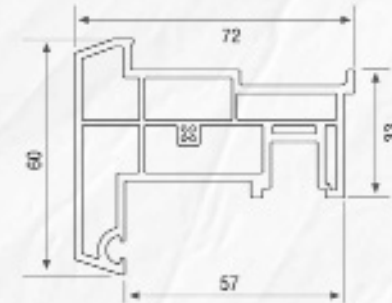

EKO ULTRA KANAT PROFİLİ / ECO ULTRA SASH PROFILE

Et Kalınlığı / Wall thickness : 2.4 mm (± 0.2)

Ağırlık / Weight : 1.470 kg/m

Kod / Code : 193010

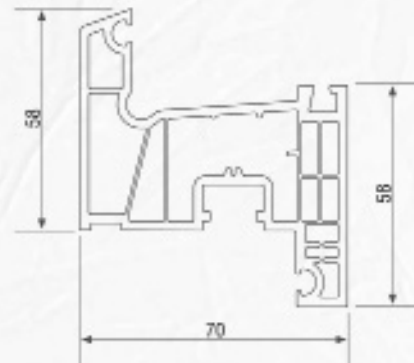

Eco Ultra Series

ULTRA DAMLALIKLI KANAT PROFİLİ / ULTRA SASH (With Water Drip) PROFILE

Et Kalınlığı / Wall thickness : 3.0 mm (± 0.2)

Ağırlık / Weight : 1.790 kg/mt

Kod / Code : 173010

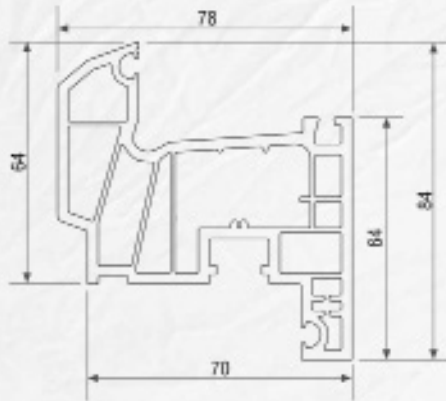

70 mm DIŞA AÇILIR KAPI PROFİLİ /

70 mm OUTSIDE OPENING DOOR PROFILE

Et Kalınlığı / Wall thickness : 3.0 mm (± 0.2)

Ağırlık / Weight : 2.100 kg/mt

Kod / Code : 175010



EKO ULTRA İÇE AÇILIR KAPI PROFİLİ /

ECO ULTRA INNER OPENING DOOR PROFILE

Et Kalınlığı / Wall thickness : 2.4 mm (± 0.2)

Ağırlık / Weight : 1.700 kg/mt

Kod / Code : 194010

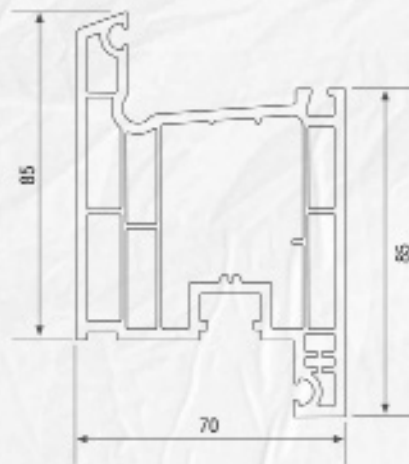

70 mm Glass Bead

Series

ULTRA TEK CAM ÇİTASI /
ULTRA SINGLE GLASS BEAD
Et Kalınlığı / Wall thickness : 2.4 mm (± 0.2)
Cam Kalınlığı / Glass thickness : 4, 5, 6
Kod / Code : 107072

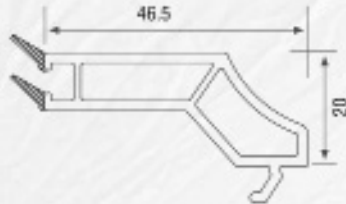

KONİK ÇİFT CAM ÇİTASI /
CONIC DOUBLE GLASS BEAD
Et Kalınlığı / Wall thickness : 2.4 mm (± 0.2)
Cam Kalınlığı / Glass thickness : 19, 20, 21
Kod / Code : 105532

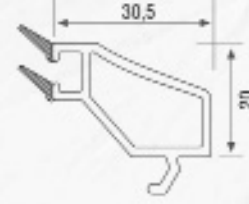

ULTRA ÇİFT CAM ÇİTASI /
ULTRA DOUBLE GLASS BEAD
Et Kalınlığı / Wall thickness : 2.0 mm (± 0.2)
Cam Kalınlığı / Glass thickness : 23, 24, 25
Kod / Code : 105092

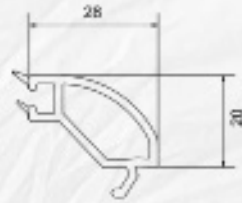

ULTRA ÜÇ CAM ÇİTASI /
ULTRA TRIO GLASS BEAD
Et Kalınlığı / Wall thickness : 2.4 mm (± 0.2)
Cam Kalınlığı / Glass thickness : 29, 30, 31
Kod / Code : 105072

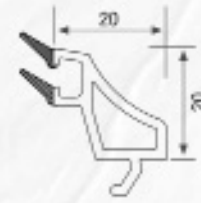

70 mm PERVAZLI
EKO ULTRA / 70 mm WITH
CASING - EKO ULTRA

KASA - ORTA KAYIT /
FRAME / MULLION

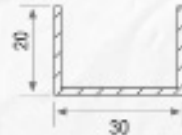

1.2 mm 618 gr
1.5 mm 761 gr
2.0 mm 963 gr

EKO ULTRA /
EKO ULTRA

KANAT / SASH

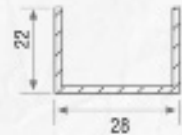

1.2 mm 636 gr
1.5 mm 784 gr
2.0 mm 1.014 gr

EKO ULTRA /
EKO ULTRA

KAPI KANAT / DOOR SASH

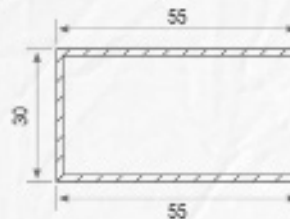

1.2 mm 1.275 gr
1.5 mm 1.584 gr
2.0 mm 2.081 gr

MENTEŞE LAMA SACI / HINGE



1.2 mm 70 gr

70 mm Auxiliary Profiles

Series

40x70mm YÜKSELTEME PROFİLİ / 40x70mm LIFTING - UP PROFILE

Et Kalınlığı / Wall thickness : 2.5 mm (± 0.2)

Ağırlık / Weight : 1.000 kg/m

Kod / Code : 171410

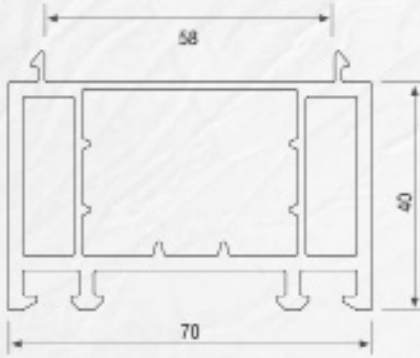

70x130mm GRIYAJ PROFİLİ / 70x130mm ENLARGING PROFILE

Et Kalınlığı / Wall thickness : 2.5 mm (± 0.2)

Ağırlık / Weight : 2.070 kg/m

Kod / Code : 171110

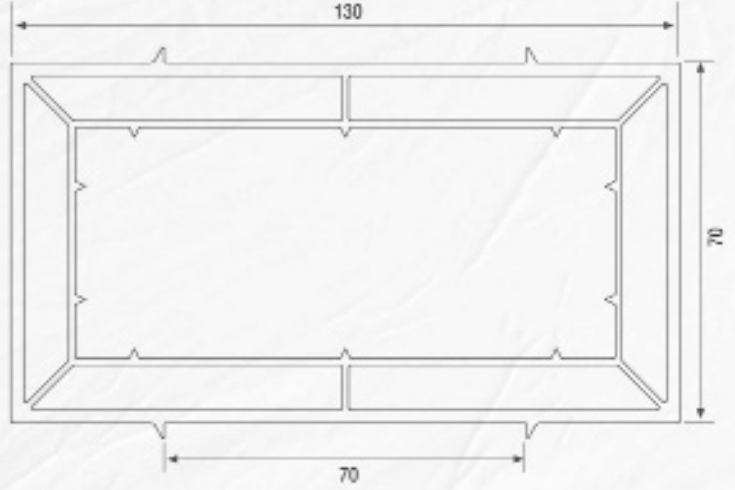

70 mm AÇILI DÖNÜŞ ADAPTÖR PROFİLİ / 70 mm ANGLED CORNER ADAPTOR PROFILE

Et Kalınlığı / Wall thickness : 2.5 mm (± 0.2)

Ağırlık / Weight : 0.610 kg/m

Kod / Code : 179010

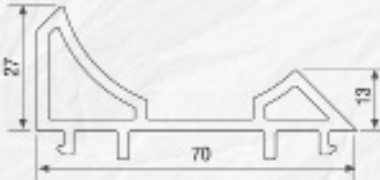

70 mm 135° KÖŞE DÖNÜŞ ADAPTÖR PROFİLİ / 70 mm 135° ANGLED CORNER ADAPTOR PROFILE

Et Kalınlığı / Wall thickness : 2.0 mm (± 0.2)

Ağırlık / Weight : 1.02 kg/m

Kod / Code : 171510

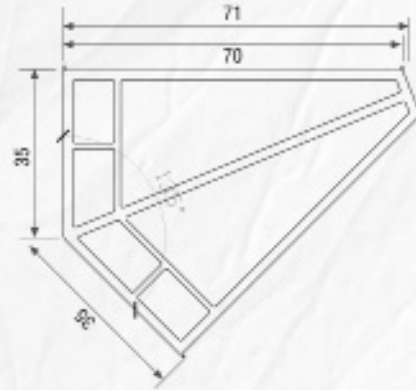

AÇILI DÖNÜŞ BORU PROFİLİ / ANGLED CORNER PIPE PROFILE

Et Kalınlığı / Wall thickness : 2.0 mm (± 0.2)

Ağırlık / Weight : 0.710 kg/m

Kod / Code : 115000



70 mm ALÜMİNYUM EŞİK PROFİLİ / 70 mm ALUMINIUM THRESHOLD PROFILE

Et Kalınlığı / Wall thickness : 2.5 mm (± 0.2)

Ağırlık / Weight : 0.600 kg/m

Kod / Code : 109010

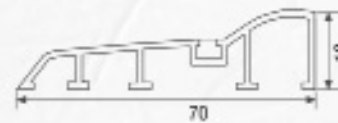

İKİ RAYLI PERVAZLI SÜRME KASA PROFİLİ /
DOBLE RAIL (With Casing) SLIDING FRAME PROFILE
Et Kalınlığı / Wall thickness : 2.5 mm (± 0.2)
Ağırlık / Weight : 1.300 kg/mt
Kod / Code : 500010

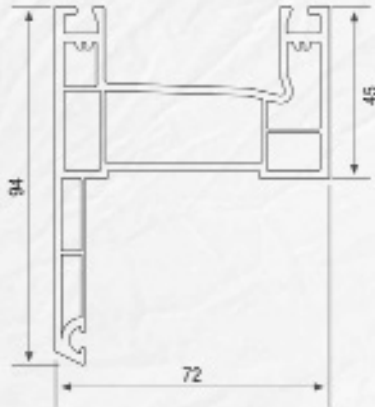

NASA SÜRME KANAT PROFİLİ /
NASA SLIDING SASH PROFILE
Et Kalınlığı / Wall thickness : 2.5 mm (± 0.2)
Ağırlık / Weight : 1.380 kg/mt
Kod / Code : 503010

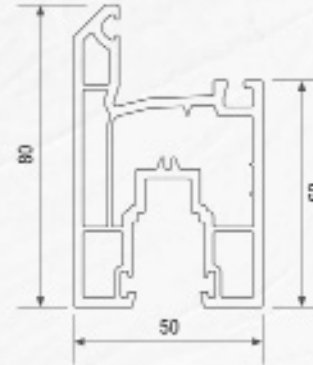

ÜÇ RAYLI SÜRME KASA PROFİLİ /
THREE RAIL SLIDING FRAME PROFILE
Et Kalınlığı / Wall thickness : 2.5 mm (± 0.2)
Ağırlık / Weight : 1.500 kg/mt
Kod / Code : 505010

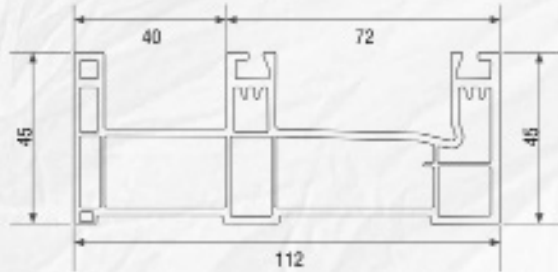

İKİ RAYLI SÜRME KASA PROFİLİ /
DOBLE RAIL SLIDING FRAME PROFILE
Et Kalınlığı / Wall thickness : 2.5 mm (± 0.2)
Ağırlık / Weight : 1.400 kg/mt
Kod / Code : 502010

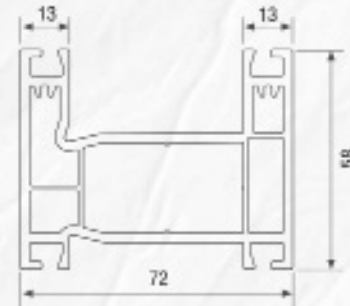

NASA ORTA KAYIT PROFİLİ /
NASA MULLION PROFILE
Et Kalınlığı / Wall thickness : 2.5 mm (± 0.2)
Ağırlık / Weight : 1.120 kg/mt
Kod / Code : 302010

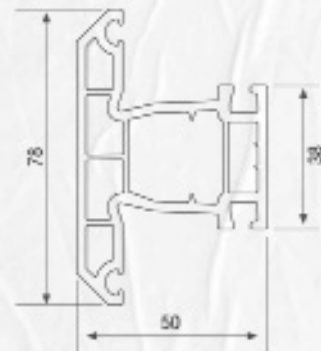

TEK RAYLI SÜRME KASA PROFİLİ /
FIXED SLIDING FRAME PROFILE
Et Kalınlığı / Wall thickness : 2.5 mm (± 0.2)
Ağırlık / Weight : 1.550 kg/mt
Kod / Code : 501010

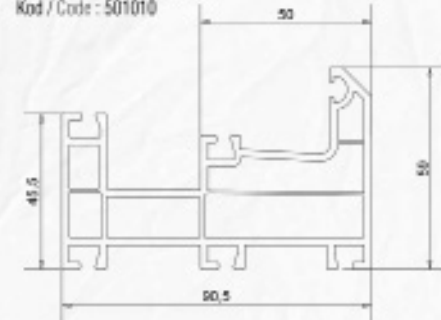

SİNEKLİK KANAT PROFİLİ / FLYSCREEN SASH PROFILE

Et Kalınlığı / Wall thickness : 1.8 mm (± 0.2)

Ağırlık / Weight : 0.700 kg/mt

Kod / Code : 503110

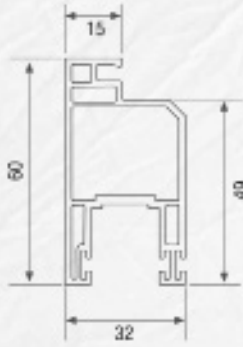

EKO İKİ RAYLI SÜRME KASA PROFİLİ /

ECO DOUBLE RAIL SLIDING FRAME PROFILE

Et Kalınlığı / Wall thickness : 2 mm (± 0.2)

Ağırlık / Weight : 0.950 kg/mt

Kod / Code : 507010

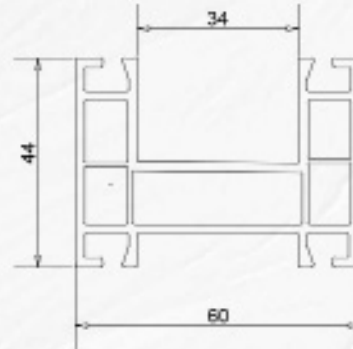

EKO SÜRME KANAT PROFİLİ /

ECO SLIDING SASH PROFILE

Et Kalınlığı / Wall thickness : 2 mm (± 0.2)

Ağırlık / Weight : 0.980 kg/mt

Kod / Code : 508010

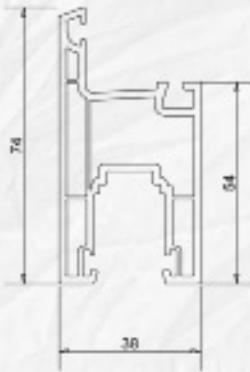

ÜÇ RAYLI PERVAZLI SÜRME KASA PROFİLİ /

THREE RAIL (With Casing) SLIDING FRAME PROFILE

Et Kalınlığı / Wall thickness : 2 mm (± 0.2)

Ağırlık / Weight : 1.800 kg/mt

Kod / Code : 506010

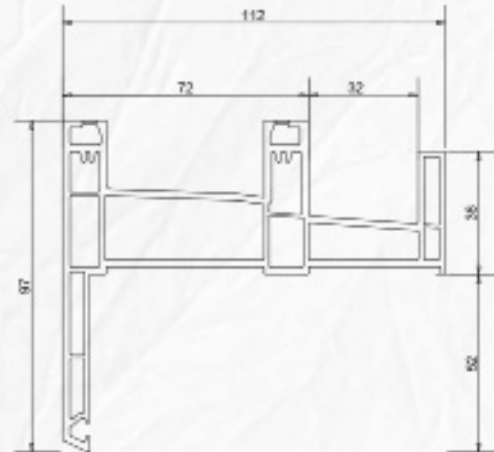

SÜRME KANAT ALIN KAPATMA PROFİLİ /

SLIDING SYSTEM COVER PROFILE (INTERLOCK)

Et Kalınlığı / Wall thickness : 2.5 mm (± 0.2)

Ağırlık / Weight : 0.320 kg/mt

Kod / Code : 504010



Nasa Auxiliary Profiles

Series

ALÜMİNYUM ALIN BİRLEŞTİRME PROFİLİ / ALUMINIUM FRONTAL CONNECTING PROFILE

Et Kalınlığı / Wall thickness : 2.5 mm (±0.2)

Ağırlık / Weight : 0.500 kg/m

Kod / Code : A-14-04

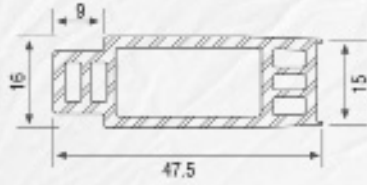

ALÜMİNYUM RAY PROFİLİ / ALUMINIUM RAIL PROFILE

Et Kalınlığı / Wall thickness : 1.5 mm (±0.2)

Ağırlık / Weight : 0.125 kg/m

Kod / Code : A-14-03

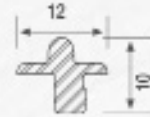

NASA TEK CAM ÇİTASI / NASA SINGLE GLASS BEAD

Et Kalınlığı / Wall thickness : 2.0 mm (±0.2)

Cam Kalınlığı / Glass thickness : 4, 5, 6

Kod / Code : 105092

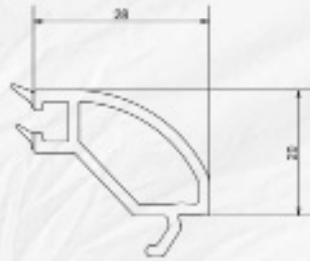

NASA ÇİFT CAM ÇİTASI / NASA DOUBLE GLASS BEAD

Et Kalınlığı / Wall thickness : 2.4 mm (±0.2)

Cam Kalınlığı / Glass thickness : 17, 18, 19

Kod / Code : 105052

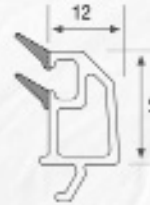

TEK RAYLI SÜRME KASA / FIXED SLIDING FRAME	İKİ RAYLI SÜRME KASA / DOUBLE RAIL SLIDING FRAME	PERVAZLI İKİ RAYLI VE ÜÇ RAYLI SÜRME KASA DOUBLE RAIL (with fringe) & TREE RAIL SLIDING FRAME																		
<table><tr><td>1.2 mm</td><td>1.048 gr</td></tr><tr><td>1.5 mm</td><td>1.287 gr</td></tr><tr><td>2.0 mm</td><td>1.685 gr</td></tr></table>	1.2 mm	1.048 gr	1.5 mm	1.287 gr	2.0 mm	1.685 gr	<table><tr><td>1.2 mm</td><td>1.087 gr</td></tr><tr><td>1.5 mm</td><td>1.358 gr</td></tr><tr><td>2.0 mm</td><td>1.812 gr</td></tr></table>	1.2 mm	1.087 gr	1.5 mm	1.358 gr	2.0 mm	1.812 gr	<table><tr><td>1.2 mm</td><td>0.956 gr</td></tr><tr><td>1.5 mm</td><td>1.194 gr</td></tr><tr><td>2.0 mm</td><td>1.594 gr</td></tr></table>	1.2 mm	0.956 gr	1.5 mm	1.194 gr	2.0 mm	1.594 gr
1.2 mm	1.048 gr																			
1.5 mm	1.287 gr																			
2.0 mm	1.685 gr																			
1.2 mm	1.087 gr																			
1.5 mm	1.358 gr																			
2.0 mm	1.812 gr																			
1.2 mm	0.956 gr																			
1.5 mm	1.194 gr																			
2.0 mm	1.594 gr																			
SÜRME SİNEKLİK KANAT / SLIDING FLYSCREEN SASH	SÜRME KANAT / SLIDING SASH	MENTEŞE LAMA SACI / HINGE																		
<table><tr><td>1.2 mm</td><td>412 gr</td></tr><tr><td>1.5 mm</td><td>503 gr</td></tr><tr><td>2.0 mm</td><td>640 gr</td></tr></table>	1.2 mm	412 gr	1.5 mm	503 gr	2.0 mm	640 gr	<table><tr><td>1.2 mm</td><td>702 gr</td></tr><tr><td>1.5 mm</td><td>865 gr</td></tr><tr><td>2.0 mm</td><td>1.123 gr</td></tr></table>	1.2 mm	702 gr	1.5 mm	865 gr	2.0 mm	1.123 gr	<table><tr><td>1.2 mm</td><td>70 gr</td></tr></table>	1.2 mm	70 gr				
1.2 mm	412 gr																			
1.5 mm	503 gr																			
2.0 mm	640 gr																			
1.2 mm	702 gr																			
1.5 mm	865 gr																			
2.0 mm	1.123 gr																			
1.2 mm	70 gr																			

Nasa Auxiliary Profiles

Series

EKO INTERLOCK PROFİLİ /

ECO INTERLOCK PROFILE

Et Kalınlığı / Wall thickness: 2 mm (+0.2)

Ağırlık / Weight: 0,330 kg/mt

Kod / Code: 509010

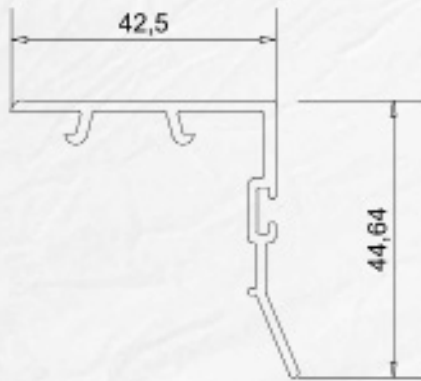

EKO İKİ RAYLI SÜRME KASA / ECO DOUBLE RAIL SLIDING FRAME	EKO SÜRME KANAT / ECO SLIDING SASH
<p>Technical drawing of the EKO İKİ RAYLI SÜRME KASA. The drawing shows a cross-section of the frame with a width of 34 mm and a height of 10,5 mm. The profile has a horizontal top flange and a vertical stem with a small downward-facing tab on the right side.</p>	<p>Technical drawing of the EKO SÜRME KANAT. The drawing shows a cross-section of the sash with a height of 19,44 mm, a width of 25,8 mm, and a top flange width of 15,61 mm. There are also smaller dimensions of 20,16 mm and 4,26 mm.</p>
ÜÇ RAYLI PERVAZLI SÜRME KASA / THREE RAIL (With Cashing) SLIDING FRAME	TEK RAYLI SÜRME KASA / FIXED SLIDING FRAME
<p>Technical drawing of the ÜÇ RAYLI PERVAZLI SÜRME KASA. The drawing shows a cross-section of the frame with a height of 17,5 mm and a width of 44 mm. The profile has a horizontal top flange and a vertical stem with a small downward-facing tab on the right side.</p>	<p>Technical drawing of the TEK RAYLI SÜRME KASA. The drawing shows a cross-section of the frame with a width of 45,5 mm and a height of 11,5 mm. The profile has a horizontal top flange and a vertical stem with a small downward-facing tab on the right side.</p>

Common Profiles

Series

PERVAZLI KAPI PROFİLİ / FRINGE DOOR PROFILE

Et Kalınlığı / Wall thickness : 2.0 mm (± 0.2)

Ağırlık / Weight : 0.750 kg/m

Kod / Code : 106000



GEÇME PERVAZ PROFİLİ / FITTING FRINGE PROFILE

Et Kalınlığı / Wall thickness : 1.5 mm (± 0.2)

Ağırlık / Weight : 0.280 kg/m

Kod / Code : 118000



KLİPSLİ PERVAZ PROFİLİ / WITH CLIPS FRINGE PROFILE

Et Kalınlığı / Wall thickness : 2.0 mm (± 0.2)

Ağırlık / Weight : 0.680 kg/m

Kod / Code : 109000

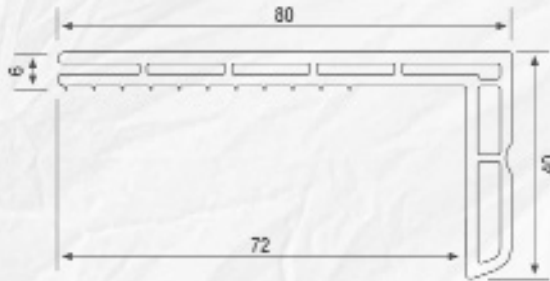

PERVAZ KLİPSİ / CLIPS FOR FRINGE

Et Kalınlığı / Wall thickness : 2.0 mm (± 0.2)

Ağırlık / Weight : 0.200 kg/m

Kod / Code : 109003



KAPATMA "T" BİNLİ PROFİLİ / "T" COVER PROFILE

Et Kalınlığı / Wall thickness : 2.5 mm (± 0.2)

Ağırlık / Weight : 0.220 kg/m

Kod / Code : 111001

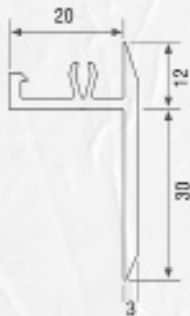

ASİMETRİK "T" BİNLİ PROFİLİ / "T" ASYMMETRIC PROFILE

Et Kalınlığı / Wall thickness : 1.5 mm (± 0.2)

Ağırlık / Weight : 0.150 kg/m

Kod / Code : 109007



Common Profiles

Series

KUTU PROFİLİ / BOX PROFILE (CORNER)

Et Kalınlığı / Wall thickness : 2.0 mm (± 0.2)

Ağırlık / Weight : 1.000 kg/mt

Kod / Code : 106070

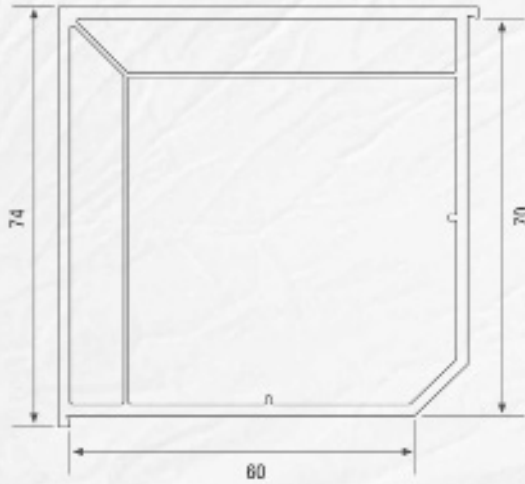

DENİZLİK ADAPTÖR PROFİLİ / SILL ADAPTOR PROFILE

Et Kalınlığı / Wall thickness : 2.5 mm (± 0.2)

Ağırlık / Weight : 0.530 kg/mt

Kod / Code : 109009

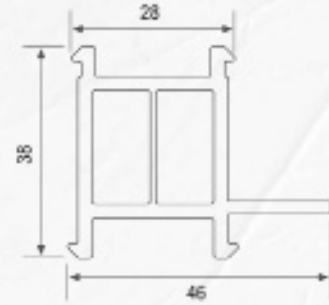

MERMER DENİZLİK ADAPTÖR PROFİLİ / MARBLE SILL ADAPTOR PROFILE

Et Kalınlığı / Wall thickness : 2.5 mm (± 0.2)

Ağırlık / Weight : 0.700 kg/mt

Kod / Code : 111000

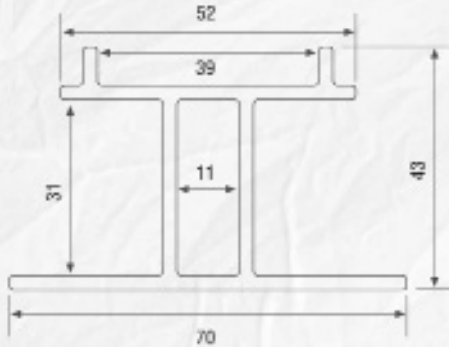

ORTAK BAĞ PROFİLİ / COMMON COUPLING PROFILE

Et Kalınlığı / Wall thickness : 2.0 mm (± 0.2)

Ağırlık / Weight : 0.100 kg/mt

Kod / Code : 109100

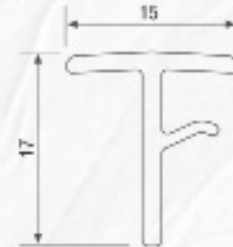

LAMBİRİ PROFİLİ / DOOR FILLER PROFILE

Et Kalınlığı / Wall thickness : 2.0 mm (± 0.2)

Ağırlık / Weight : 0.730 kg/mt

Kod / Code : 108000

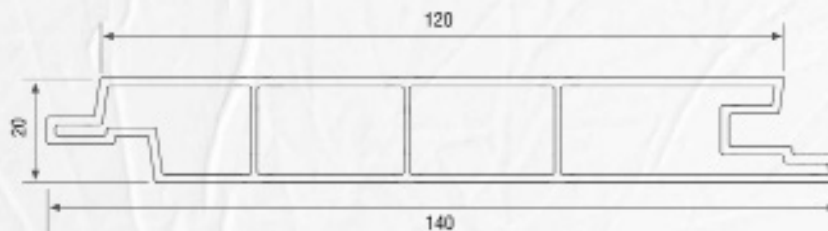

KANAL KAPATMA PROFİLİ / FEELING PROFILE

Et Kalınlığı / Wall thickness : 2.5 mm (± 0.2)

Ağırlık / Weight : 0.080 kg/mt

Kod / Code : 109008





GBU



and Quality...

Tilt & Turn Series

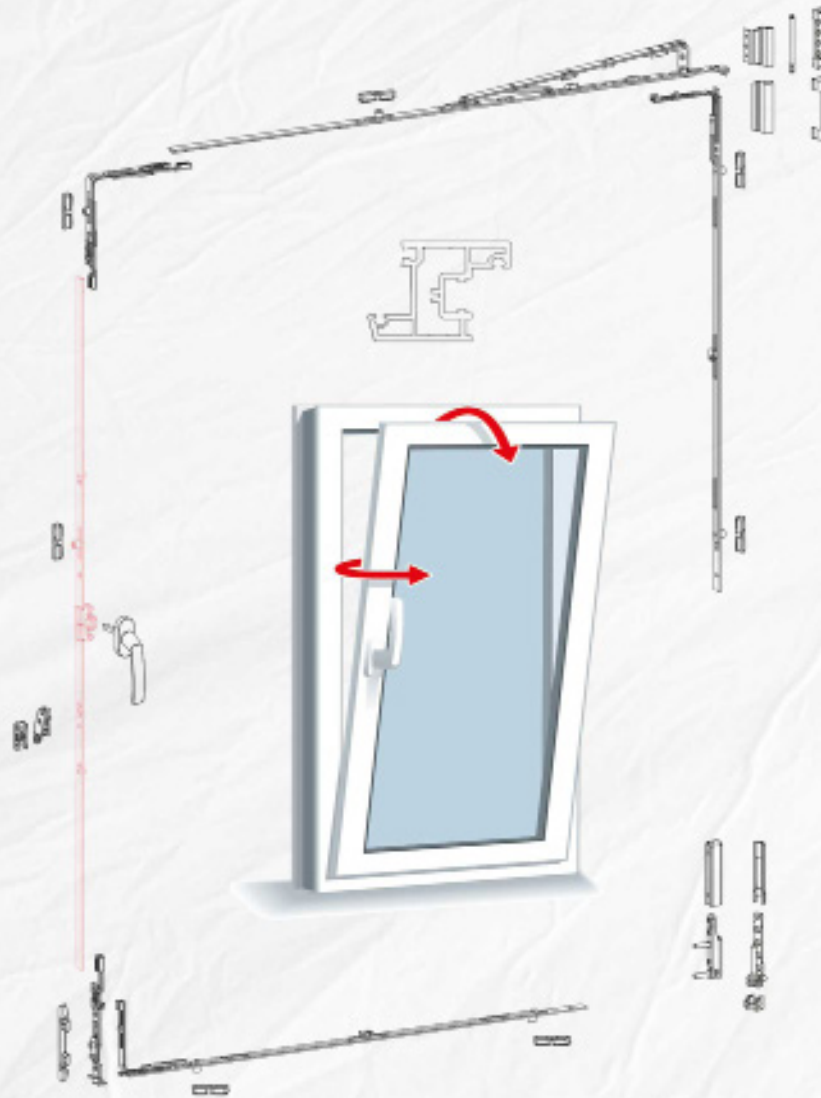

"TILT AND TURN SYSTEMS" أنظمة الفتح والإمالة		SASH WIDTH (MM) العرض			
SASH HEIGHT (MM) الطول		350-600	400-650	650-900	900-1154
500-700		TTS-01	TTS-02	TTS-03	TTS-04
700-1200		TTS-05	TTS-06	TTS-07	TTS-08
900-1400		TTS-09	TTS-10	TTS-11	TTS-12
1200-1700		TTS-13	TTS-14	TTS-15	TTS-16
1700-2200		TTS-17	TTS-18	TTS-19	TTS-20
1900-2400		TTS-21	TTS-22	TTS-23	TTS-24

Espagnolette

Series

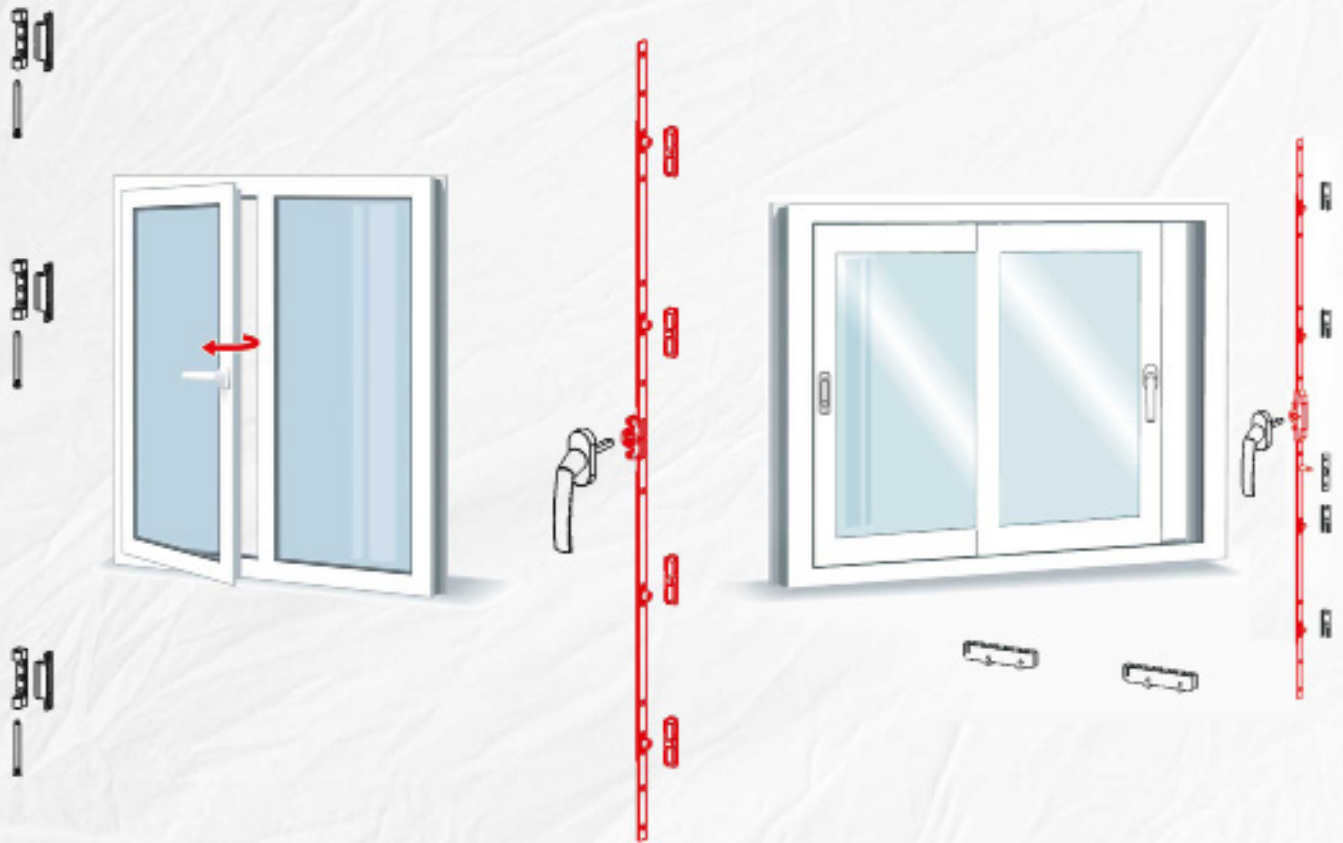

اسبنيول عادي ("TURN ONLY SYSTEM (ESPAGNOLETTE)")			
SASH HEIGHT(MM) الطول	STEEL	ZINC	
400mm	TAS-01	TAZ-01	
600mm	TAS-02	TAZ-02	
800mm	TAS-03	TAZ-03	
1000mm	TAS-04	TAZ-04	
1200mm	TAS-05	TAZ-05	
1400mm	TAS-06	TAZ-06	
1600mm	TAS-07	TAZ-07	
1800mm	TAS-08	TAZ-08	
2000mm	TAS-09	TAZ-09	

اسبنيول سحاب ("TURN ONLY SLIDING SYSTEM (ESPAGNOLETTE)")			
SASH HEIGHT(MM) الطول	STEEL	ZINC	
400mm	SAS-01	SAZ-01	
600mm	SAS-02	SAZ-02	
800mm	SAS-03	SAZ-03	
1000mm	SAS-04	SAZ-04	
1200mm	SAS-05	SAZ-05	
1400mm	SAS-06	SAZ-06	
1600mm	SAS-07	SAZ-07	
1800mm	SAS-08	SAZ-08	
2000mm	SAS-09	SAZ-09	

Locked Espagnolette

Series

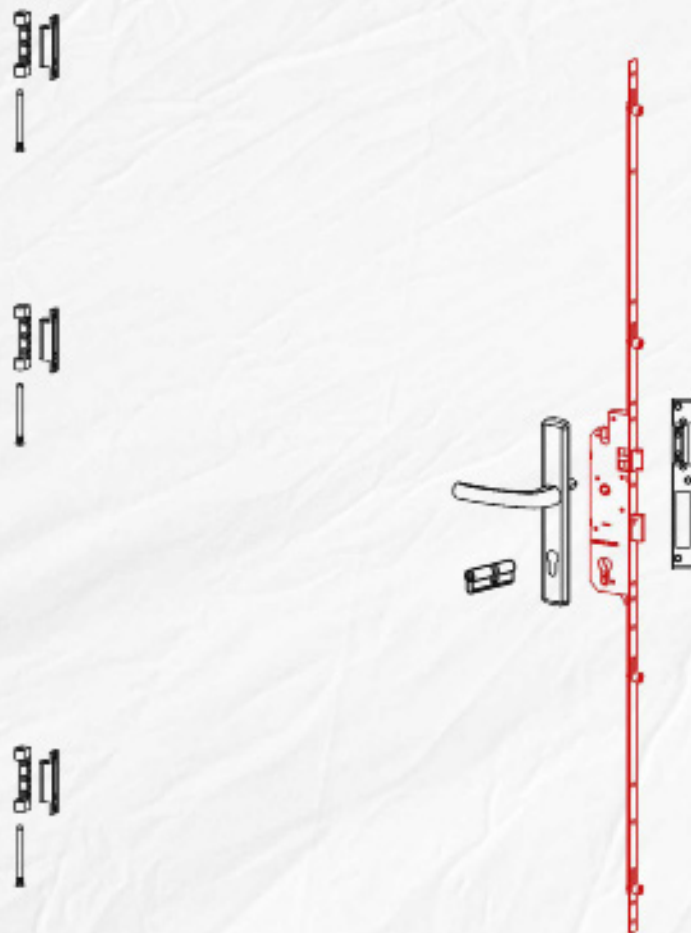

"LOCKED ESPAGNOLETTE" اسبتيول مع قفل

CYLINDER LOCKED DOOR ESPAG. 1800MM. اسبتيول مع قفل	SKI-01
CYLINDER LOCKED DOOR ESPAG. 2000MM. اسبتيول مع قفل	SKI-02
WC LOCKED DOOR ESPAG. 1800MM. اسبتيول مع قفل حمام	WKI-01
WC LOCKED DOOR ESPAG. 2000MM. اسبتيول مع قفل حمام	WKI-02

Lock & Cylinder

Series

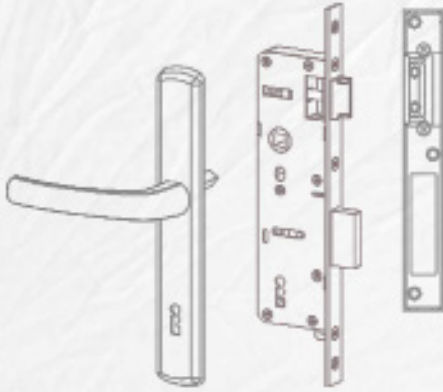

"CYLINDER" سلندر

DOOR CYLINDER 90MM	سلندر باب 90 MM	KB-01
WC DOOR CYLINDER 90MM KNOCKER	سلندر باب حمام 90 MM	WKB-01

"LOCK" قفل

DOOR LOCK	قفل باب	KK-01
WC DOOR LOCK	قفل باب حمام	WKK-01

Locking Plates & Mullion Connectors

Series



TAK-T01



TAK-C01



KKK-K01



KKK-U01



SK-01



OKBT

"LOCKING PLATES" مقابل قفل		
DOOR LOCKING PLATES (SHORT)	مقابل قفل باب قصير	KKK-K01
DOOR LOCKING PLATES (LONG)	مقابل قفل باب طويل	KKK-U01
ESPAGNOLETTE PLATES (ONE HOLE)	مقابل اسبنيول ثقب واحد	TAK-T01
ESPAGNOLETTE PLATES (DOUBLE HOLE)	مقابل اسبنيول ثقبين	TAK-C01
SLIDING ESPAGNOLETTE PLATES	مقابل اسبنيول سحب	SK-01

"MULLION CONNECTORS" ربط تي		STEEL	ZINC
OKBT	ربط تي	OKBT-S01	OKBT-Z01

Handle Group

Series



MPK-01



EKK-01



EPK-01



MWK-01



MKK-01



SGK-01



MK-01

"HANDLE GROUP" مجموعة المقابض

"HANDLE GROUP" مجموعة المقابض		
MILANO WINDOW HANDLE	مقبض نافذة ميلانو	MPK-01
MILANO DOOR HANDLE	مقبض باب ميلانو	MKK-01
MILANO DOOR WC HANDLE	مقبض باب حمام ميلانو	MWK-01
EGE WINDOW HANDLE	مقبض نافذة ايجة	EPK-01
EGE DOOR HANDLE	مقبض باب ايجة	EKK-01
EGE DOOR WC HANDLE	مقبض باب حمام ايجة	EWK-01
MOSTER DOOR HANDLE	مقبض باب موستر	MK-01
POP-UP SLIDING HANDLE	مقبض سحب مخفي	SGK-01

Hinge Group

Series



"HINGE GROUP SYSTEMS" المفصلات		
75mm ALUMINUM HINGE	مفصلات المنيوم 75 mm	ALM-75
95mm ALUMINUM HINGE	مفصلات المنيوم 95 mm	ALM-95
75mm PLASTIC IRON HINGE	مفصلات بلاستيك حديد 75 mm	PLM-75
90mm PLASTIC IRON HINGE	مفصلات بلاستيك حديد 90 mm	PLM-90
75mm ZINC HINGE	مفصلات زنك 75 mm	ZMM-75
100mm ZINC HINGE	مفصلات زنك 100 mm	ZMM-100
3D HINGE (125kg)	مفصلات ثري دي 125 kg	3D-125
3D HINGE (160kg)	مفصلات ثري دي 160 kg	3D-160

Screw Group

Series



SELF DRILLING SCREWS FLAT HEAD	براني	TYPE
MUV100202		3,9x16 YHB
MUV100203		3,9x19 YHB
MUV100204		3,9x22 YHB
MUV100205		3,9x25 YHB
MUV100206		3,9x32 YHB
MUV100225		4,2x45 YHB



DRWALL SCREWS FLAT HEAD	براني	TYPE
BSY100505		3,9x25 YHB



CONCRETE SCREWS	براني	TYPE
TRK100402		7,5x80
TRK100403		7,5x100
TRK100406		7,5x150



SELF TAPPING SCREWS	براني	TYPE
MNJ100609		4,8x50 YSB
MNJ100610		4,8x60 YSB

Transom Group System

Series

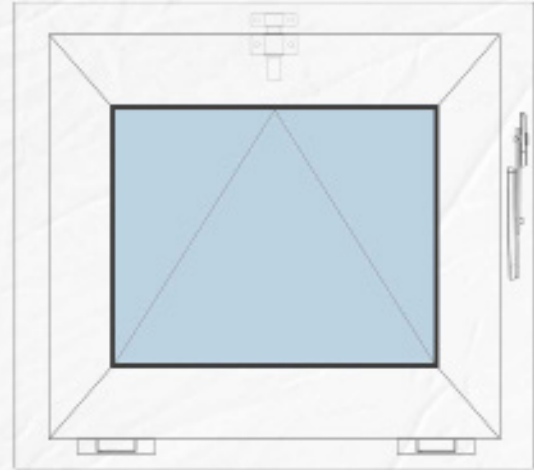
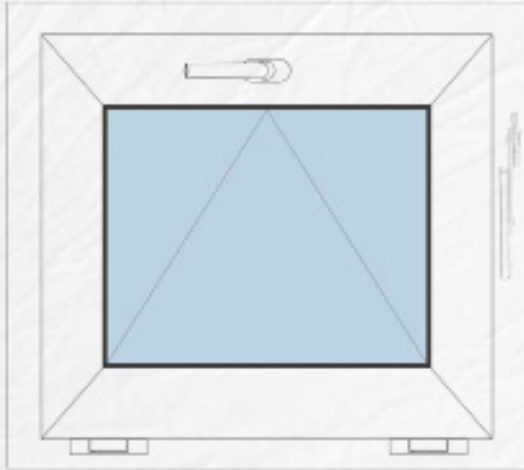

نظام فتح امالة للحمام "TRANSOM GROUP SYSTEM"		
TRANSOM SCISSORS 130mm R:9016	مقص فتح امالة ابيض	VM-01
TRANSOM SCISSORS 130mm STEEL	مقص فتح امالة لون الحديد	VMS-01
TRANSOM LOCK PLASTIC	مقبض فتح امالة بلاستيك	PAV-01

Sliding Wheel & Safety Latch

Series

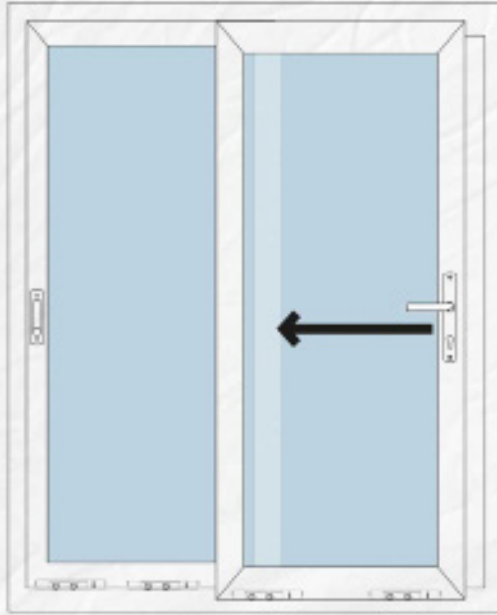

EM-01



EMK-01

"SAFETY LATCH" حماية		
SAFETY LATCH	مزلاج حماية	EM-01
SAFETY LATCH LOCKED	مزلاج حماية مع قفل	EMK-01

"SLIDING WHEEL" دولاب سحاب		
BRASS SLIDING DOUBLE WHEEL	دولاب سحاب لتنائي نحاس	PST-01

Plastic Products & Lock Strikers

Series



WATER DASHBOARD PLUG



BULDEX SCREW PLUG



MONTAGE PLUG



STICKY TEFLON



LEAK STOPPERS



MULLION CONNECTORS



ADJUSTABLE WEDGE OF GLASS



WEDGE OF GLASS



DOUBLE AIR VALVE

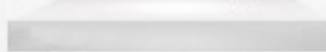

SASH LIFTING WEDGE



GLASS SHOVEL



GBU



Protective material

Aluminum Profile & Tulle

Series



OSS-1026

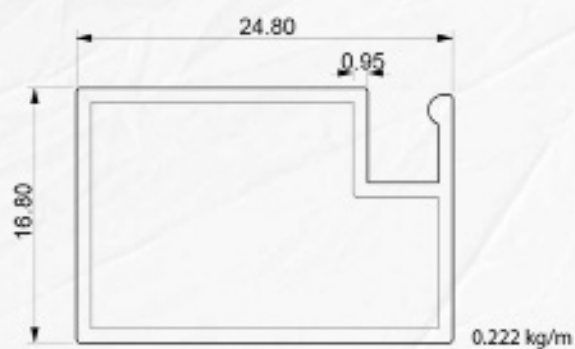

OSS-1022

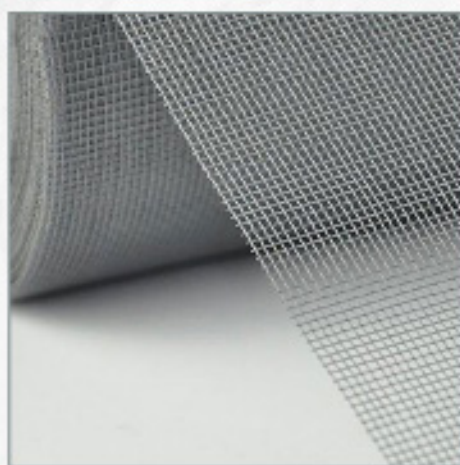
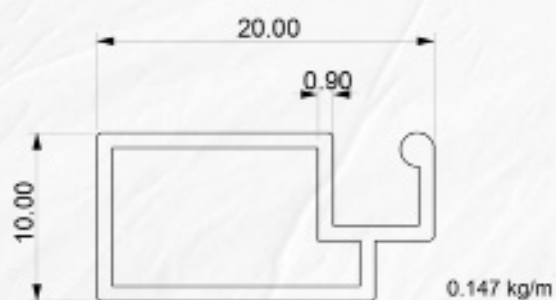

PS 02

Fly Screen

Series



PK 02

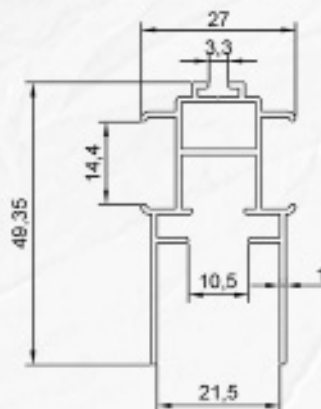

PK 01

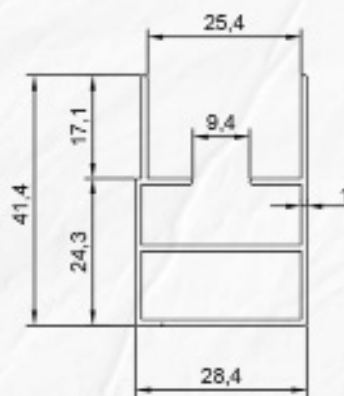

PS 02

Fly Screen

Series



PVC Strip Tape



Plise Rope



Double Sided Tape



Plise Flyscreen Set

Flyscreen Accessory

Series

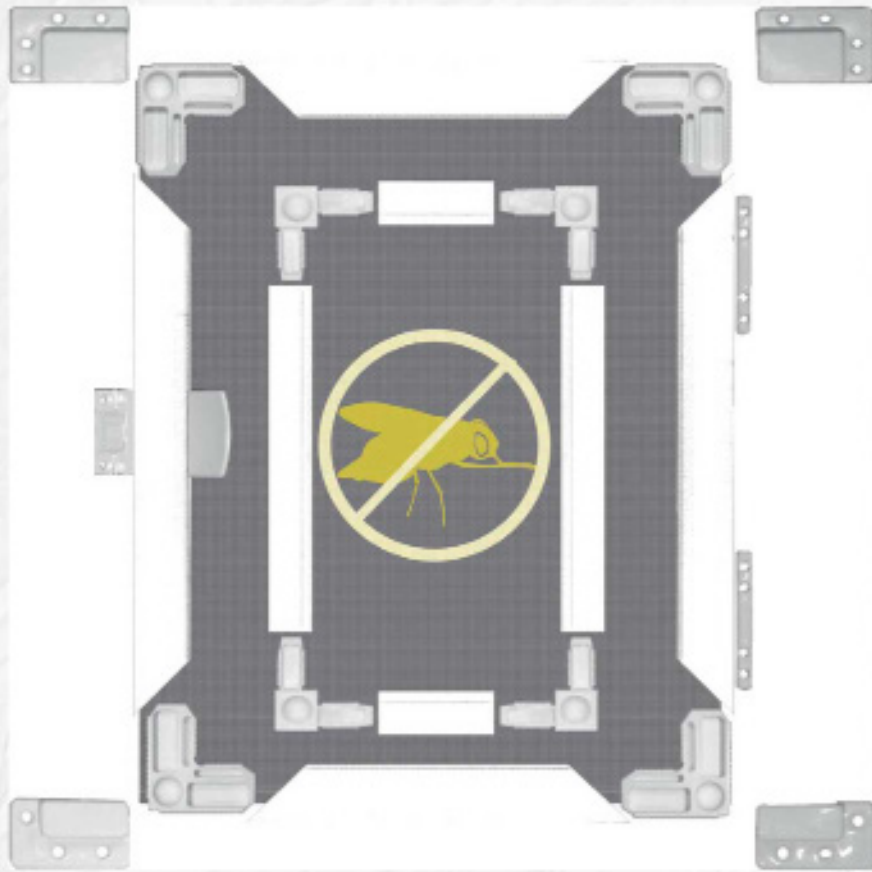

ASG001



ASG002



ASG003



ASG004



ASG005



ASG006



ASG007



ASG008



ASG009



ASG029



ASG030



ASG031



GBU



Aesthetic appearance

Pana Stone

Series

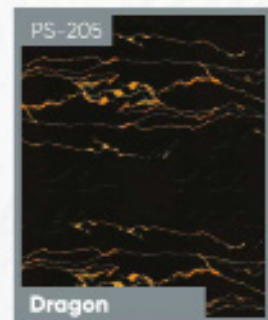
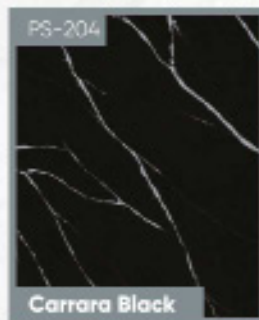
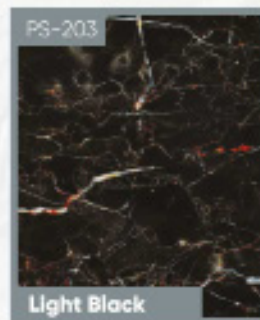
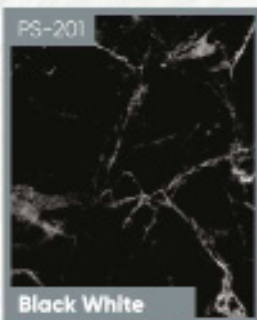
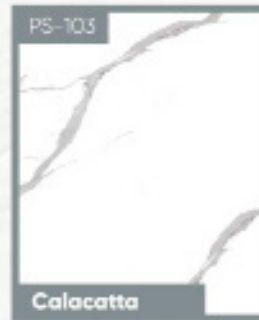
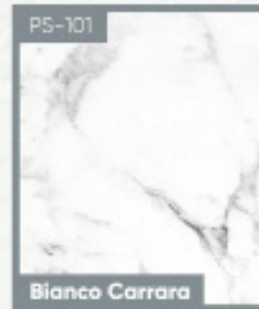
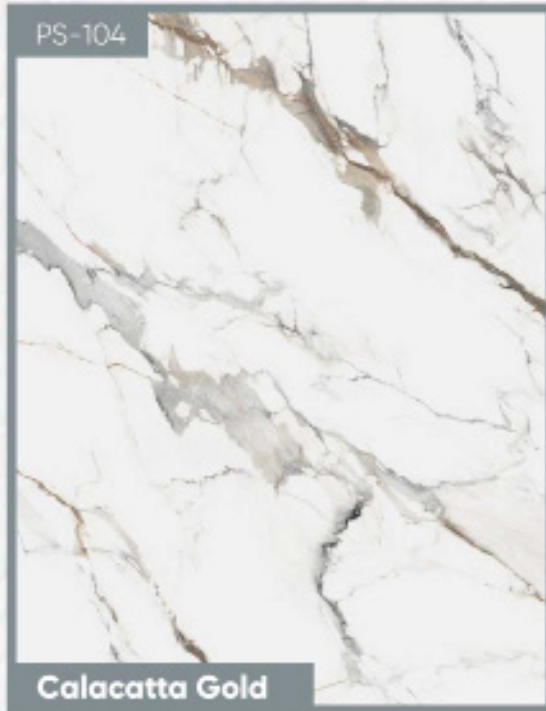

Dimensions: **1220x2800 mm**
Thickness: **2.80 mm**

Pana Stone

Series

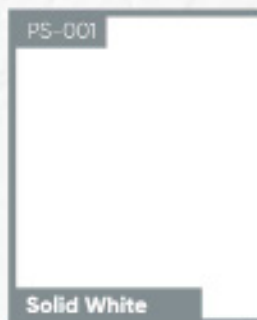
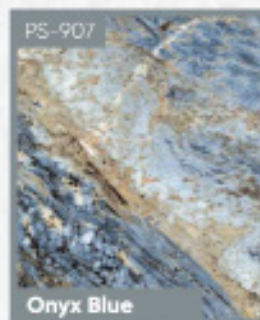
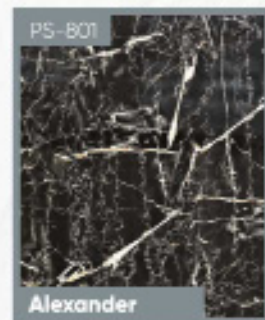
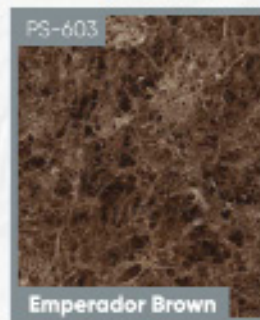
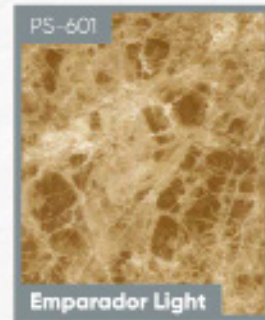
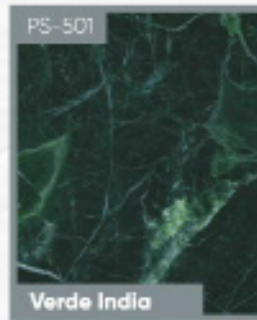
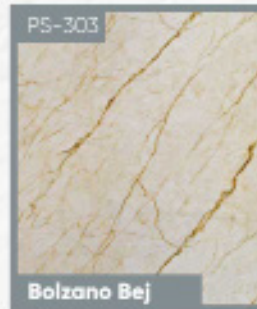

Dimensions: **1220x2800 mm**
Thickness: **2.80 mm**

Pana Stone

Series

Application Areas

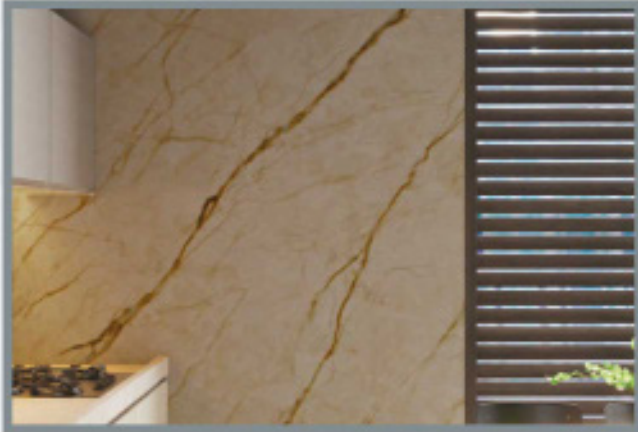

Aluminium Profiles

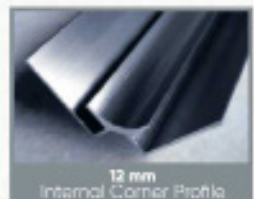
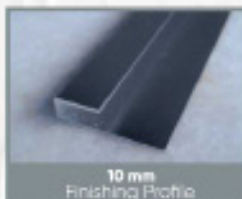
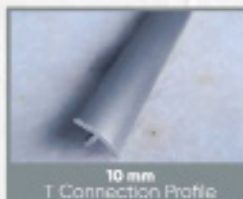
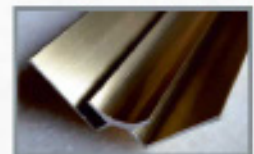
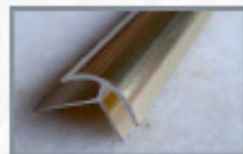
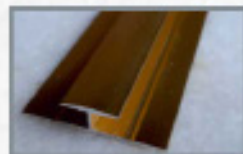
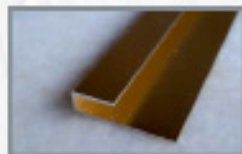



GBU



Decorative Collection

Panels Group

Series

Thermo Door Collection

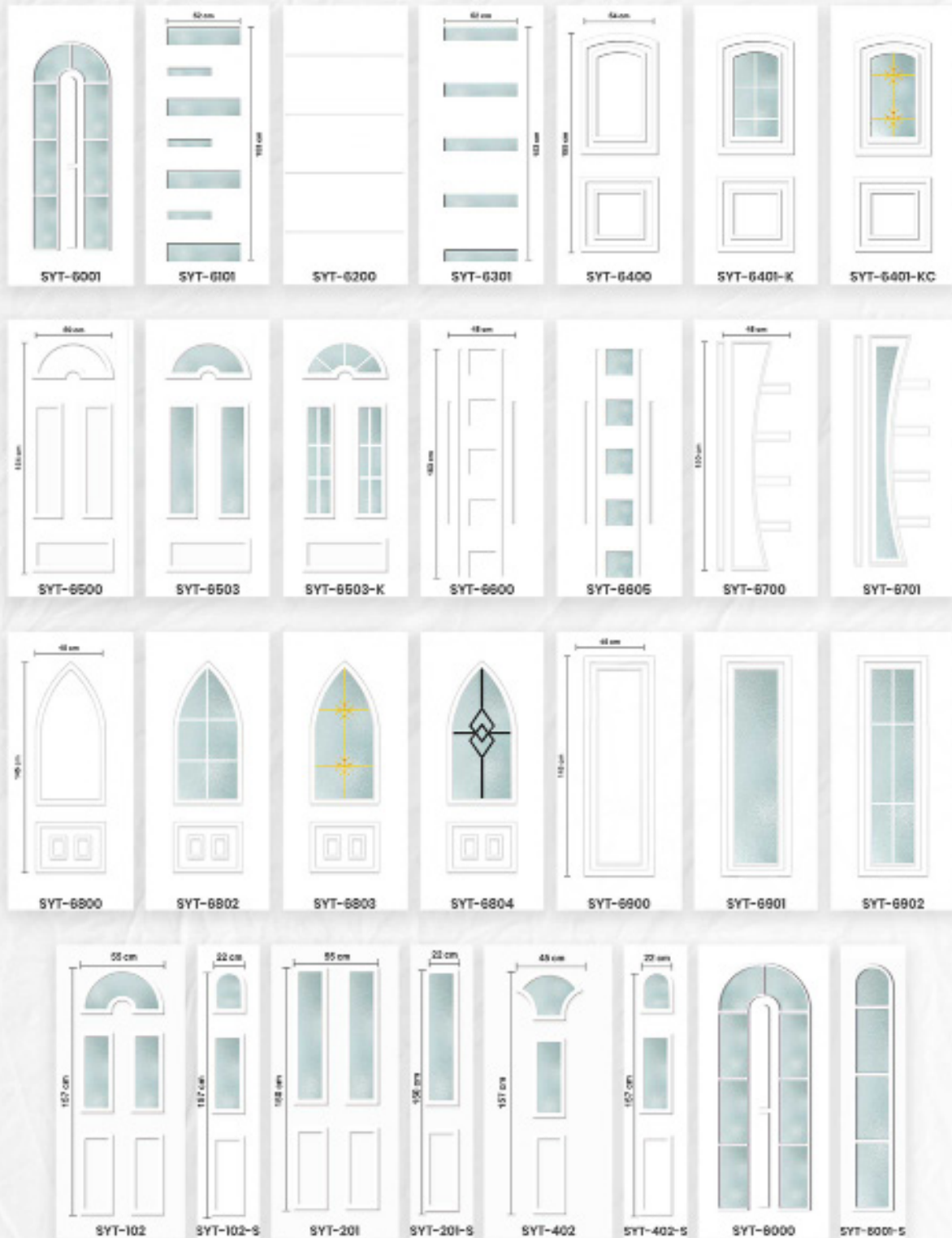

Decorative Bar Colour Options

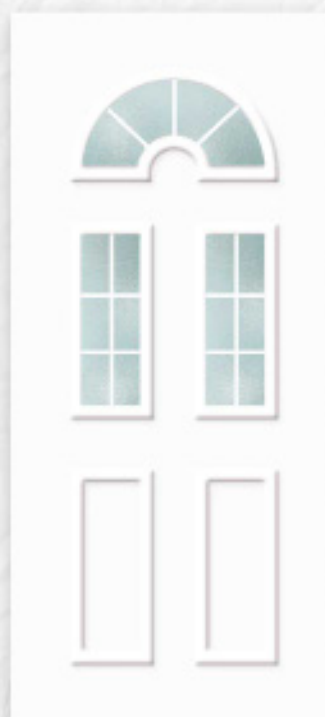

White Bar

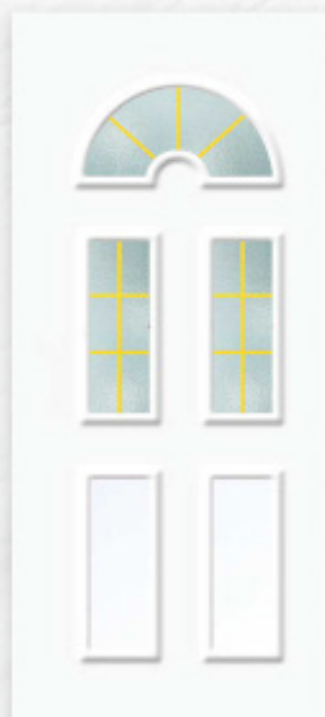

Golden Bar



Black Bar

Glazing Options

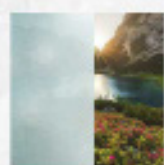

Frosted Glass

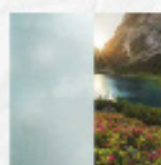

Satin Glass

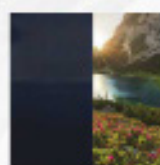

Reflective Glass

**Standart glass is frosted glass.*

***Production time may be longer for glass other than frosted glass.*

Composition Options



XPS



MDF+XPS+MDF



XPS+MDF+XPS

**Standart dimensions are 20 mm and 24 mm.*

***Panel thickness available up to 44 mm.*

Colour Options



White
Ral 9016



Anthracite



Golden Oak



Black



Walnut



White
Ral 9010

Dimension: 870x2050x20/24 mm, UV-protected PVC sheet, 10YEARS GUARANTEE



GBU

The easy and efficient way to produce
Double Glazing!

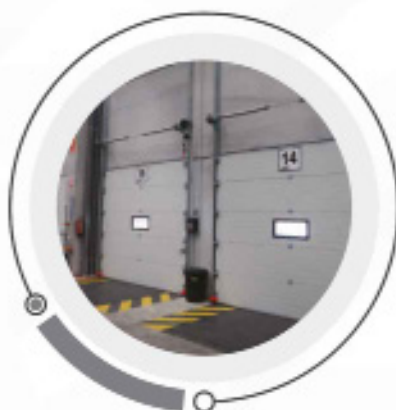

Sectional Garage
Doors



Triple Glass



Refrigerators



Bus Glass



All Shapes



Windows and
Door Glass

Easy application!

Double Glass Spacer

Series

SPACER BARS



Standart Spacer Bars

Packing Information of Standart, Bendable, Painted Spacer Bars						
Dimension		Length				
A (mm)	H (mm)	2.80 (m)	5.80 (m)	5.70 (m)	6.00 (m)	Pieces/box
5,5	6,5	1350	2250	2505	2700	450
7,5	6,5	1350	2300	2304	2520	420
8,5	6,5	1340	1900	2106	2280	380
9,5	6,5	1620	1700	1918	2040	340
10,5	6,5	900	1500	1710	1800	300
11,5	6,5	840	1400	1586	1680	280
13,5	6,5	720	1200	1368	1440	240
14,5	6,5	800	1300	1254	1320	220
15,5	6,5	800	1800	1140	1200	200
17,5	6,5	540	900	1035	1080	180
19,5	6,5	480	800	912	960	160
21,5	6,5	420	700	798	840	140
23,5	6,5	420	700	755	840	140
26,5	6,5	360	600	684	720	120



Bendable Spacer Bars

Packing Information of Butyled Spacer Bars				
Dimension		Length		
A (mm)	H (mm)	2.80 (m)	5.80 (m)	Pieces/box
5,5	6,5	1900	2900	500
7,5	6,5	1800	1670	324
8,5	6,5	1800	1670	314
9,5	6,5	1800	1670	314
10,5	6,5	1800	1670	314
11,5	6,5	1800	1670	314
13,5	6,5	750	1200	250
14,5	6,5	750	1200	250
15,5	6,5	750	1200	250
17,5	6,5	800	800	180
19,5	6,5	800	800	180
21,5	6,5	800	800	180
23,5	6,5	800	800	180
26,5	6,5	800	800	180



Painted Spacer Bars



Butyled Spacer Bars

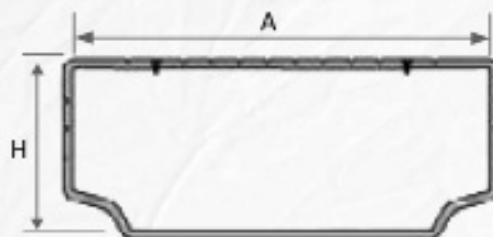

Double Glass Spacer

Series

CONNECTORS

Metal connectors for bendable spacer bars

Dimension (mm)	
5.5	
7.5	
8.5	
9.5	
10.5	
11.5	
13.5	
14.5	
15.5	
17.5	
19.5	
21.5	
23.5	



Plastic connectors for bendable spacer bars

Dimension (mm)	
5.5	
7.5	
8.5	
9.5	
10.5	
11.5	
13.5	
14.5	
15.5	
17.5	
19.5	
21.5	
23.5	



Connectors for standard spacer bars

Dimension (mm)	
5.5	
7.5	
8.5	
9.5	
10.5	
11.5	
13.5	
14.5	
15.5	
17.5	
19.5	
21.5	
23.5	



Gas filled connectors and plugs

Dimension (mm)	
5.5	
7.5	
8.5	
9.5	
10.5	
11.5	
13.5	
14.5	
15.5	
17.5	
19.5	



MOLECULAR SIEVE



POLYSULPHIDE

A Component 190 lt	B Component 19 lt	A Component 52 lt	B Component 6 lt	A Component 16 lt	B Component 2 lt
					

Double Glass Spacer

Series

ISO-TECH (IT)

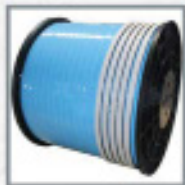
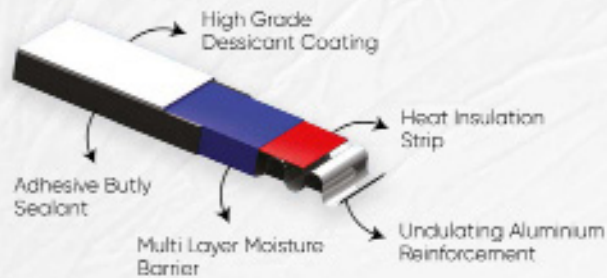

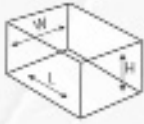
TYPE	THICKNESS	BOX/ROLL LENGHT	PACK DIMENSIONS
MAXI TECH	6 MM	400 METER	 L = 48 cm W = 41 cm H = 41 cm
ISO TECH	8 MM	370 METER	
ISO TECH	8 MM	350 METER	
ISO TECH	10 MM	300 METER	
ISO TECH	11 MM	280 METER	
ISO TECH	12 MM	270 METER	
ISO TECH	14 MM	250 METER	
ISO TECH	16 MM	220 METER	
ISO TECH	17 MM	190 METER	
ISO TECH	18 MM	180 METER	
ISO TECH	20 MM	175 METER	
ISO TECH	24 MM	150 METER	
MAXI TECH	10 MM	300 METER	
MAXI TECH	12 MM	270 METER	
MAXI TECH	16 MM	200 METER	
MAXI TECH	20 MM	175 METER	

ISO-TECH (IT)

Panapacer ISOTECH is an insulating warm edge seal system constructed using an advance composite laminating technology. ISOTECH is manufactured with high quality components, sealants, aluminium and desiccant to create a super performance durable spacer system.

- Triple laminating technology
- Aluminium reinforcement element, non conductivity material
- Strong adhesive technology, resistable climate conditions, high moisture resistance
- High performance argon conservation
- Easy packaging and easy application
- %52 better U insulation value than traditional aluminium bars
- High sound insulation
- Easy application on round and different shaped glasses
- Fast and easy production solutions
- Lower investment cost compared to old systems
- Available in standart sizes and also speciale sizes upon customer request





GBU

The latest technology

Isolation Group

Series



High Tack



Fast Pasting



GP Transparent

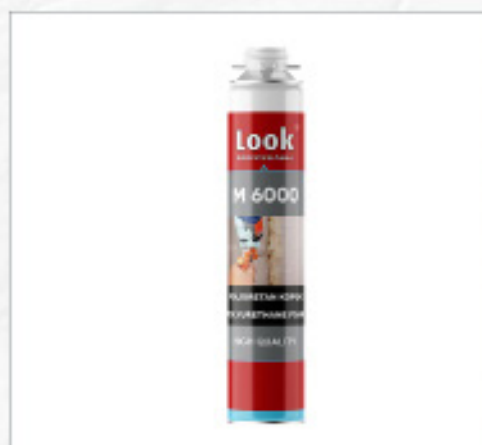

Foam



Siliconized Sealant G 1000



Siliconized Sealant B 300



GBU

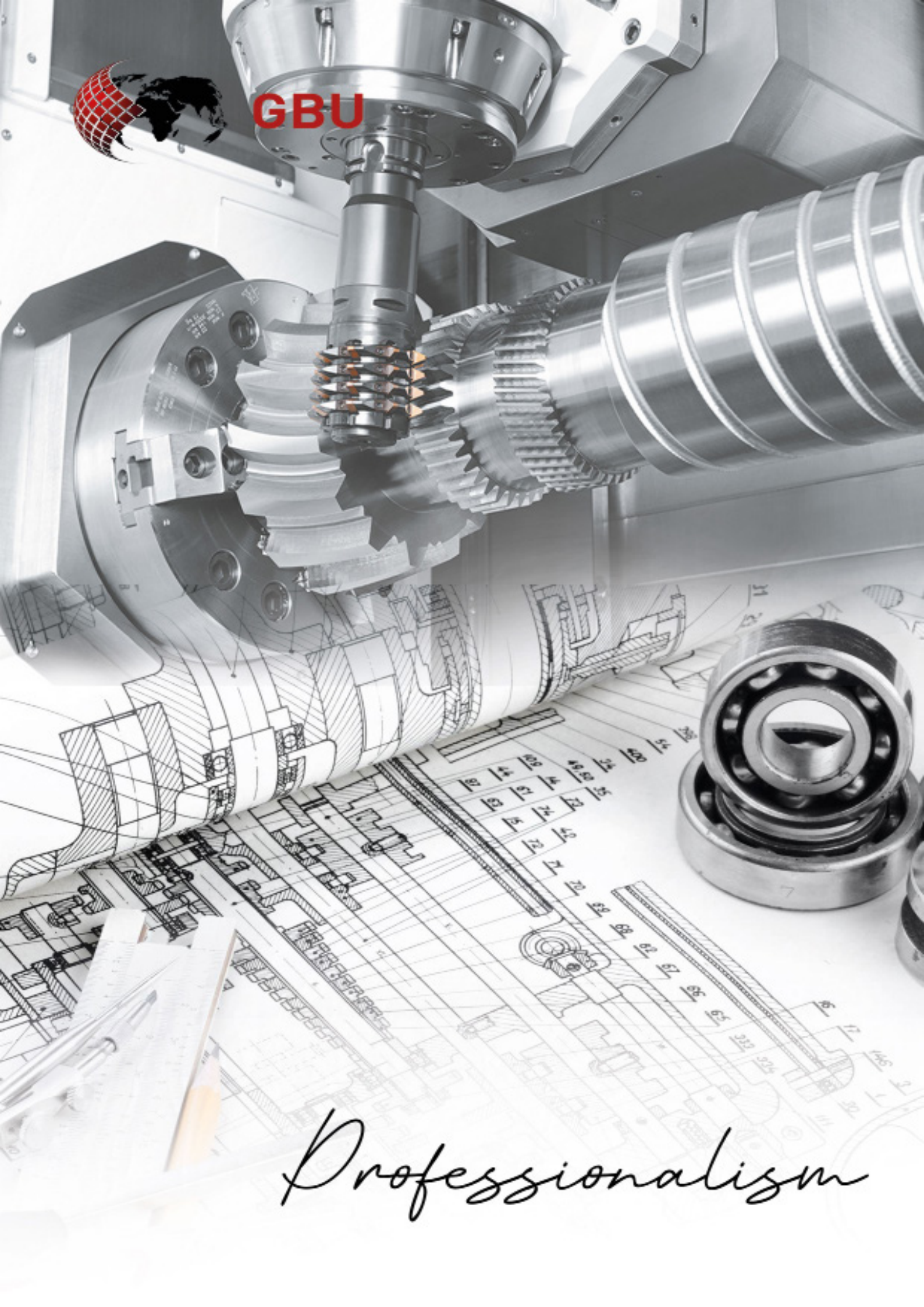

Professionalism

Machine Group

Series



ISO-111
0.02 mm Single Head
Welding Machine



ISO-201
Automatic Glazing
Bead Saw



ISO-301
Automatic and Milling
Machine



ISO-401
Automatic Single
Head Mitre Saw



ISO-501
Automatic Corner
Cleaning Machine



ISO-601
Automatic Copy Router
With Triple Drill and Drain Slot

Machine Group

Series



ISO-701

PVC Automatic Double
Head Welding Machine



ISO-801

Automatic Digitally Controlled
Double Head Cutting Machine

Machine Group

Series



ISO-101 A
Manual Welding
Machine



ISO-221 A
Manual Glazing
Bead Saw



ISO-632
Manual Copy Router



ISO-321
Manual End Milling



GN-400
Portable Cutting
Machine



ISO-500 A
Surface Cleaning
Apparatus



HBP 01
Hydraulic Corner
Joint Press



CM-35
Automatic Meter

Machine Group

Series

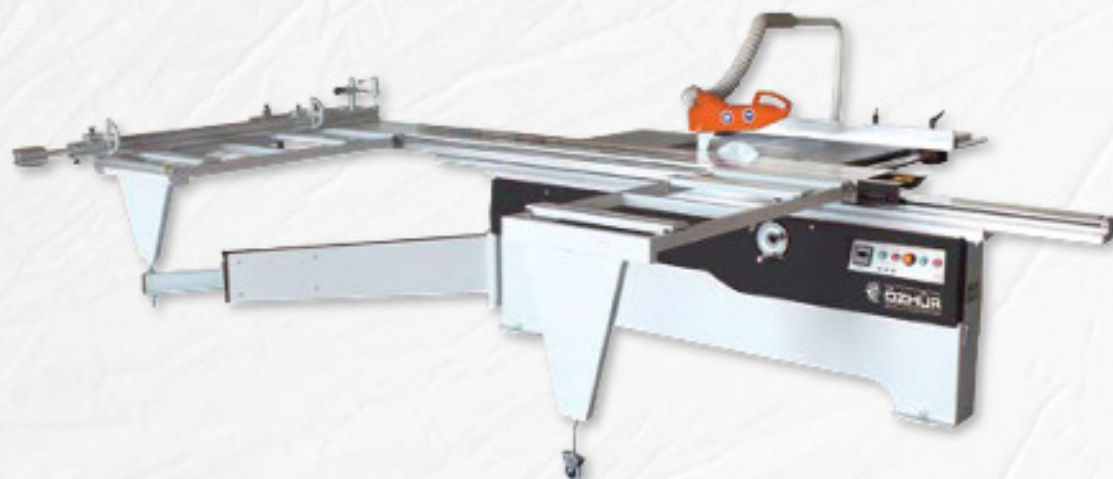

SWN 2200/ SWN 2800
SWN 3200/ SWN 3800
Circular Panel Saw



KBM 1060
Edge Banding Machine

Double Glass Spacer

Series

HOT PRESS MACHINE



PR-190 Technical Details

	Glass Preparation Table	Extension Group	Hot Press Machine	Cut & Measure Table
Pressing Distance			0-50 mm	
Length	1800 mm	540 mm	1250 mm	800 mm
Width	1680 mm	2180 mm	1600 mm	2180 mm
Height	1000 mm	1000 mm	1500 mm	980 mm
Voltage	230 V	-----	380 V /	-----
Frequency	50-60 Hz	-----	50-60 Hz	-----
Power	0,6 kW	-----	13 kW	-----
Air Pressure	6 bar (1800m ³ /h)	-----	6 bar (1800m ³ /h)	-----
Weight	275 kg	175 kg	550 kg	180 kg



PR-180 Technical Details

	Glass Preparation Table	Extension Group	Hot Press Machine	Cut & Measure Table
Pressing Distance			0-50 mm	
Length	2120 mm	540 mm	1400 mm	800 mm
Width	1800 mm	2180 mm	1500 mm	2180 mm
Height	1000 mm	1000 mm	1500 mm	980 mm
Voltage	230 V	-----	380 V /	-----
Frequency	50-60 Hz	-----	50-60 Hz	-----
Power	0,6 kW	-----	20 kW	-----
Air Pressure	6 bar (1800m ³ /h)	-----	6 bar (1800m ³ /h)	-----
Weight	275 kg	175 kg	750 kg	180 kg



PR-210 Technical Details

	Glass Preparation Table	Extension Group	Hot Press Machine	Cut & Measure Table
Pressing Distance			0-50 mm	
Length	2120 mm	540 mm	1400 mm	800 mm
Width	1800 mm	2180 mm	1525 mm	2180 mm
Height	1000 mm	1000 mm	1500 mm	980 mm
Voltage	230 V	-----	380 V /	-----
Frequency	50-60 Hz	-----	50-60 Hz	-----
Power	0,6 kW	-----	25 kW	-----
Air Pressure	6 bar (1800m ³ /h)	-----	6 bar (1800m ³ /h)	-----
Weight	270 kg	175 kg	850 kg	180 kg



PR-100 Technical Details

	Glass Preparation Table	Hot Press Machine
Pressing Distance		30-50 mm
Length	2120 mm	685 mm
Width	2120 mm	945 mm
Height	820 mm	205 mm
Voltage	230 V	230 V
Frequency	50 Hz	50 Hz
Power	0,6 kW	4,4 kW
Air Pressure	6 bar	-----
Weight	190 kg	80 kg

Double Glass Spacer

Series

GLASS CLEANING MACHINE



Code	CYM 130 1300 MM-4 Brushes	CYM 150 1700 MM-4 Brushes	CYM 230 2000 MM-4 Brushes
Workable Glass Area	Min: 250x250 mm Min: 1300x1300 mm	Min: 250x350 mm Min: 1700x3500 mm	Min: 250x250 mm Min: 2000x3000 mm
Length	7000 mm	8000 mm	8000 mm
Width	1000 mm	1000 mm	2000 mm
Height	2300 mm	2600 mm	3000 mm
Weight	1200 kg	1700 kg	2000 kg
Voltage	380~400V 3 NPE AC	380~400V 3 NPE AC	380~400V 3 NPE AC
Frequency	50 Hz	50 Hz	50 Hz
Power	7.5 kW	7.5 kW	7.5 kW

AUTOMATIC ARGON FILLING MACHINE



Code	ADM
Length	1030 mm
Width	400 mm
Height	730 mm
Weight	80 kg
Voltage	220~380V 3 NPE AC
Frequency	50 Hz



GBU



Powerful Creation

Round Railing Profiles

Series

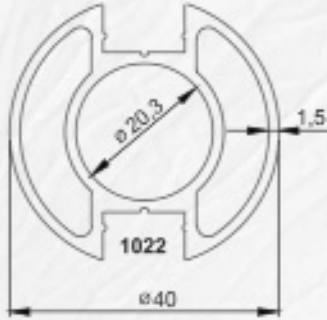

■ 1565

40'lık Çift Kanal Dikme Profili 1,5mm
0,911 kg/m

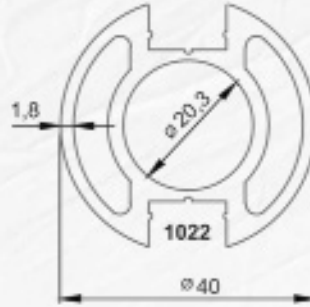

■ 1010

40'lık Çift Kanal Dikme Profili 1,8mm
1,143 kg/m

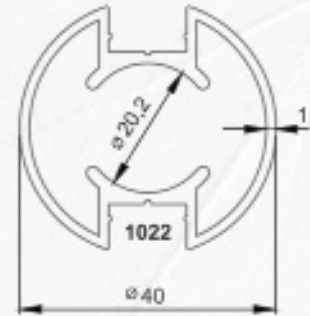

■ 1599

40'lık Çift Kanal Dikme Profili 1,5
0,762 kg/m

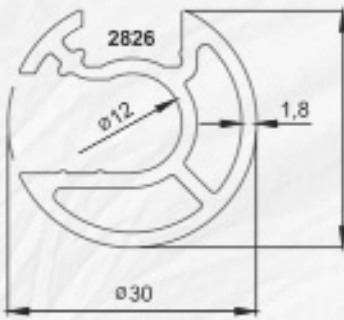

■ 2825

30'lık Dikme Profili Camlı 1,8mm
0,598 kg/m

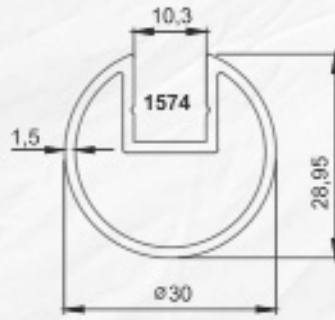

■ 1570

30'lık Kanallı Profil 1,5mm
0,467 kg/m

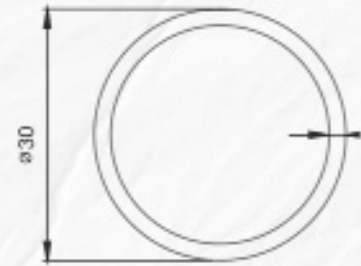

■ 1571

30'lık Boru 2mm
0,477 kg/m

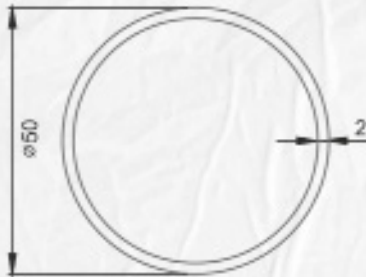

■ 896

50'lık Boru 2mm
0,817 kg/m

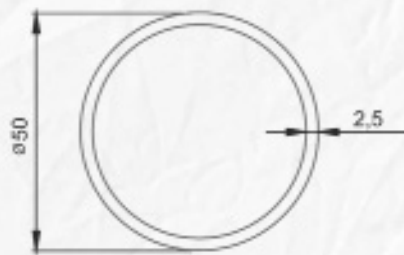

■ 917

50'lık Boru 2,5mm
1,011 kg/m

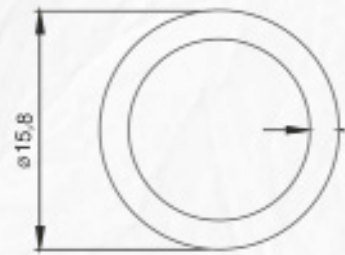

■ 1234

16'lık Boru 1,9mm
0,224 kg/m

Round Railing Profiles

Series

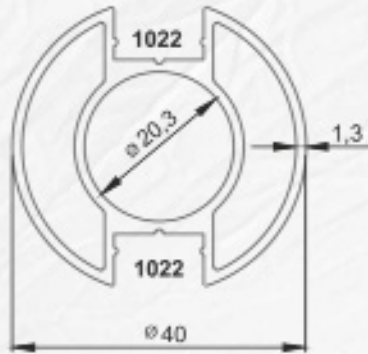

■ 2879

40'lık Çift Kanal Dikme Profili 1,3mm
0,755 kg/m

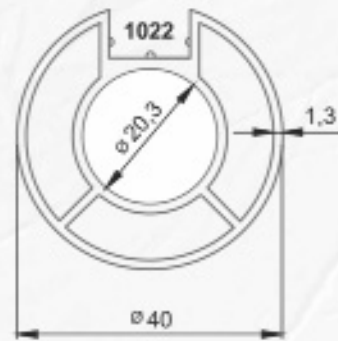

■ 2246

40'lık Tek Kanal Dikme Profili 1,3mm
0,806 kg/m

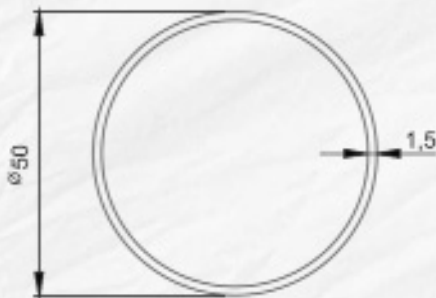

■ 2622

50'lık Boru 1,5mm
0,620 kg/m

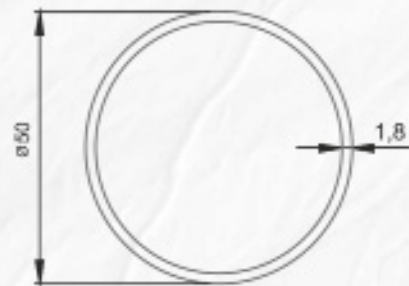

■ 2984

50'lık Boru 1,8mm
0,738 kg/m

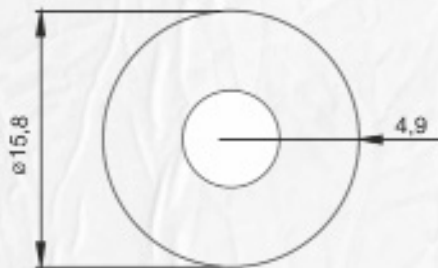

■ 916

16'lık Boru 4,9mm
0,454 kg/m

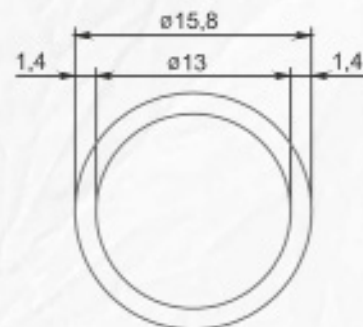

■ 2878

16'lık Boru 1,4mm
0,172 kg/m

Round Handrail Accessories

Series



40' Upper Connection Extrusion



Top Link Set of 50



40' Strut Flange



40' Fixed Joint



Gooseneck Connection Straight



50' Bracelet



16' Pipe Handle Piece



16' Pipe Handle



50 Plug



40 Plug

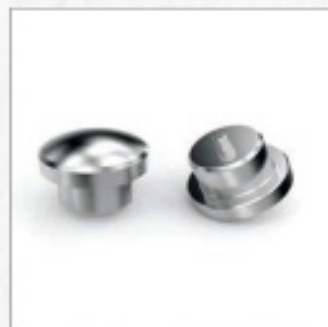

16 Plug



16 and 19 inch Decorated Plug

Round Handrail Accessories

Series



16" Aluminum Screw Hiding



Glass Clip with Twill Cover



50" Inflatable Elbow 90



50" Inflatable Elbow 45



50" Solid Knob Elbow



50" Eco Knob Elbow



50" External Screw Wall Flange



40" External Screw Wall Flange



50" Wall Flange

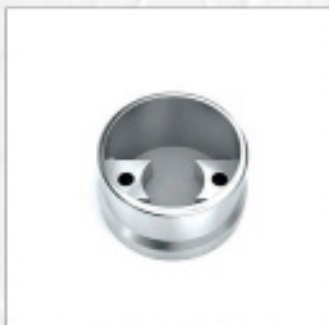

50" Wall Flange Double

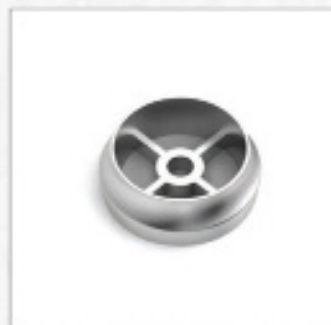

40" Wall Flange

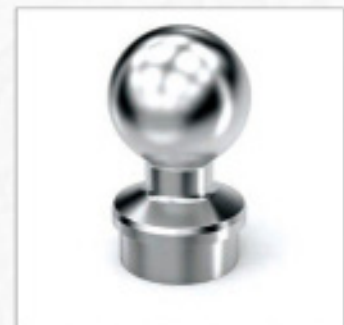

40" Starter Knob
50" Starter Knob

Round Handrail Accessories

Series



40 Side U Connection



Railing Hinge



Railing Slider



Grinding Iron 15 cm



Wall Side Connection Kit



Epoxy



Marble Adherence Grout



Epoxy Gun



Big Erection



Big Erection



Middle Strut





GBU



Hardware Group

Series



Portable Cutting Machine
300 mm



Portable Cutting Machine
with Tilting Head 300 mm



HPK 50
Section and Pipe Banding
Machine



KH 2002
Glass Cutter



KH 3038
Glass Drilling Measured Cutter



KH 3036
Glass Cutter

Hardware Group

Series



OPT 4080-6(R+L)
Screw Driver



OPT 4080-8(R+L)
Screw Driver



OPT (R+L)
Pneumatic Drill



OPT 103R
Air Rivet Pistol



OPT 124
Air Die Grinder



OPT 120
Air Die Grinder



OPT 3042
Air Control Unit



OPT 3012
Air Control Unit

Hardware Group

Series



KH 3061
Professional Silicon Gun



KH 3062
Plastic Silicon Gun



KH 3062
Glass Scraping Blade



KH 3071
Plastic Maket Blade



KH 3070
Plastic Maket Blade



KH 3074
White Screw Knob



Drill Bit

Hardware Group

Series



Nitrile Work Glove



Beybi Glass Rubber Glove



Nora Strip Meters



Fisko Strip Meters



Stanley Strip Meters



Stanley Strip Meters

Our Activities

Nos Activités

Les processus de projet, d'analyse, de chiffrage et d'appel d'offres de pièces métalliques des principaux secteurs de l'automobile, des machines, de la construction, des machines agricoles et des machines minières sont réalisés par nos équipes d'experts.

Projets acier de construction

Nous fabriquons des
Ouvrages de construction
En acier léger et en acier
Lourd dans l'industrie de la
Construction selon le projet.



Projets de fabrication soudés
Soudage à l'électrode
Fabrication soudeée
Soudage au gazine
Soudage à l'argon



Projets D'acier Lourd.



Our Activities

Nos Activités

Projets en acier léger



L'industrie des machines est le secteur industriel de base qui répond aux besoins de fabrication et de maintenance de machines des branches industrielles opérant économiquement dans des domaines tels que l'agriculture, les transports et la défense. En tant que Soyla Metal, nous fournissons une assistance dans les processus de découpe-torsion-soudage-usinage-peinture de pièces de machines de l'industrie des machines.



Nous réalisons des opérations de découpe de tôles – pliage – fabrication mécano-soudée – usinage de machines agricoles.



Our Activities

Nos Activités

L'INDUSTRIE DES MACHINES EST LE SECTEUR INDUSTRIEL DE BASE qui répond aux besoins de fabrication et de maintenance de machines des branches industrielles opérant économiquement dans des domaines tels que l'agriculture, les transports et la défense. En tant que Soyla Metal, nous fournissons une assistance dans les processus de découpe-torsion-soudage-usinage-peinture de pièces de machines de l'industrie des machines.

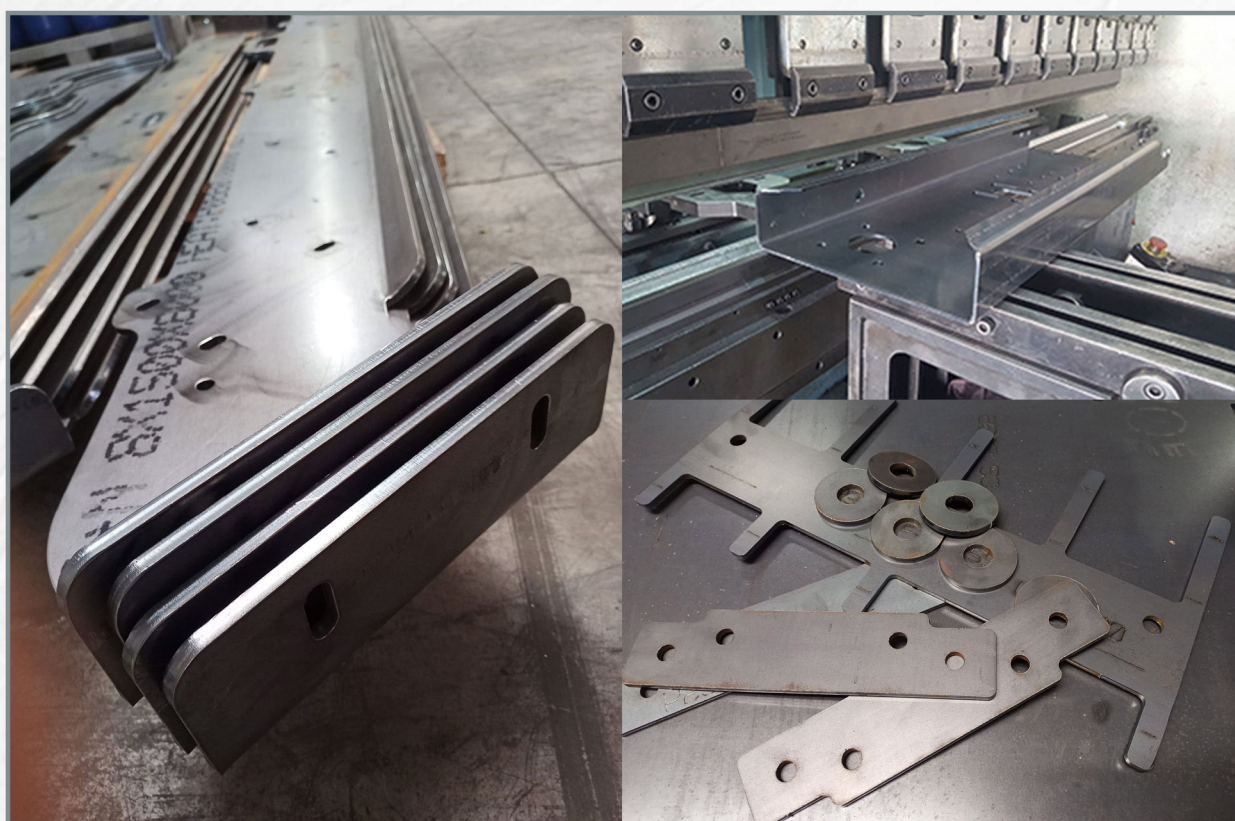



GBU

GBU PLASTİK YAPI ELM. İTH. İHR. SAN. TİC. LTD. ŞTİ.

Soğanlık Yeni Mahalle Baltacı Mehmet Paşa Sokak
AC MOMENT Plaza No:4 (B) Blok/18
Kartal / İstanbul - TÜRKİYE

+90 539 218 8963

info@gbuplastik.com

www.gbuplastik.com

